



# Tsi721™ Datasheet

April 4, 2016



# Table of Contents

- About this Document ..... 6
  - Overview ..... 6
  - Document Conventions ..... 6
  - Revision History ..... 7
- 1. Device Overview ..... 8
  - 1.1 Overview ..... 8
  - 1.2 Features ..... 8
    - 1.2.1 PCIe Features ..... 8
    - 1.2.2 S-RIO Features ..... 9
    - 1.2.3 Bridging Features ..... 9
    - 1.2.4 Messaging Features ..... 10
    - 1.2.5 Block DMA Engine Features ..... 10
    - 1.2.6 Miscellaneous Features ..... 11
  - 1.3 Block Diagram ..... 12
    - 1.3.1 PCIe Interface ..... 12
    - 1.3.2 S-RIO Interface ..... 12
    - 1.3.3 Messaging Engine ..... 12
    - 1.3.4 Mapping Engine ..... 12
    - 1.3.5 Block DMA Engine ..... 12
  - 1.4 Typical Applications ..... 13
    - 1.4.1 Defense/Aerospace Application ..... 13
    - 1.4.2 Video and Imaging Application ..... 15
    - 1.4.3 Wireless Application ..... 15
- 2. Signals ..... 17
  - 2.1 Overview ..... 17
  - 2.2 Ballmap ..... 18
  - 2.3 Pinlist ..... 19
  - 2.4 PCIe Signals ..... 19
  - 2.5 S-RIO Signals ..... 20
  - 2.6 General Signals ..... 20
  - 2.7 I2C Signals ..... 21
  - 2.8 JTAG and Test Interface Signals ..... 21
  - 2.9 GPIO Signals ..... 22
  - 2.10 Power-up Signals ..... 23
  - 2.11 Power Supply Signals ..... 26
- 3. Electrical Characteristics ..... 27
  - 3.1 Absolute Maximum Ratings ..... 27
  - 3.2 Recommended Operating Conditions ..... 28
  - 3.3 Power Consumption ..... 28

3.4	Power Supply Sequencing.....	29
3.4.1	Power-Up Sequencing.....	29
3.4.2	Power-Down Sequencing.....	29
3.5	DC Operating Characteristics .....	30
3.6	Decoupling Recommendation.....	31
3.7	AC Timing Specifications .....	31
3.7.1	PCIe Differential Receiver Specifications .....	31
3.7.2	PCIe Differential Transmitter Specifications .....	34
3.7.3	RapidIO SerDes Characteristics.....	38
3.7.4	Level I Long Run Transmitter Specifications .....	43
3.7.5	Reference Clocks – PCCLKP/N and REFCLKP/N .....	57
3.7.6	JTAG and Test Interface Signal Timings .....	59
3.7.7	I2C Interface Signal Timings .....	60
3.7.8	GPIO Interface Signal Timings .....	61
3.7.9	RSTn Signal Timings.....	61
4.	Package Specifications.....	62
4.1	Package Dimensions .....	62
4.2	Package Diagrams.....	63
4.3	Thermal Characteristics .....	64
4.4	Moisture Sensitivity.....	64
5.	Ordering Information .....	65



## List of Figures

Figure 1:	Block Diagram.....	12
Figure 2:	Defense/Aerospace Application .....	14
Figure 3:	Video and Imaging Application .....	15
Figure 4:	Wireless Application .....	16
Figure 5:	Ballmap .....	18
Figure 6:	S-RIO Definition of Transmitter Amplitude and Swing .....	39
Figure 7:	S-RIO Transition Symbol Transmit Eye Mask.....	44
Figure 8:	S-RIO Single Frequency Sinusoidal Jitter Limits .....	46
Figure 9:	S-RIO Level I Receiver Input Mask.....	47
Figure 10:	Transition and Steady State Symbol Eye Mask .....	51
Figure 11:	Level II Receiver Input Compliance Mask.....	56
Figure 12:	HCSL to REFCLKP/N / PCCLKP/N .....	58
Figure 13:	LVDS to REFCLKP/N / PCCLKP/N.....	58
Figure 14:	LVPECL to REFCLKP/N / PCCLKP/N .....	58
Figure 15:	LVPECL to REFCLKP/N / PCCLKP/N .....	59
Figure 16:	I2C Interface Signal Timings.....	60
Figure 17:	Package Diagrams.....	63



## List of Tables

Table 1:	Signal Types .....	17
Table 2:	PCIe Signals .....	19
Table 3:	S-RIO Signals .....	20
Table 4:	General Signals .....	20
Table 5:	I2C Signals.....	21
Table 6:	JTAG Interface Signals .....	21
Table 7:	GPIO Signals .....	22
Table 8:	GPIO Mapping to Power-up Signals .....	22
Table 9:	Power-Up Signals .....	23
Table 10:	Power Supply Signals .....	26
Table 11:	Absolute Maximum Ratings .....	27
Table 12:	Recommended Operating Conditions .....	28
Table 13:	Power Consumption.....	28
Table 14:	Power Supply Sequencing Ramp Times .....	29
Table 15:	3.3V LVTTTL DC Operating Characteristics at Recommended Operating Condition of 3.3V .....	30
Table 16:	2.5V LVTTTL DC Operating Characteristics at Recommended Operating Condition of 2.5V .....	30
Table 17:	Decoupling Recommendation.....	31
Table 18:	PCIe Differential Receiver Specifications .....	31
Table 19:	PCIe Differential Transmitter Specifications.....	34
Table 20:	Level I Short Run Transmitter AC Timing Specifications .....	42
Table 21:	Level I Long Run Transmitter AC Timing Specifications.....	43
Table 22:	Level I Near-End (Tx) Template Intervals .....	44
Table 23:	Level I Receiver Electrical Input Specifications .....	45
Table 24:	Level I Receiver Input Jitter Tolerance Specifications.....	46
Table 25:	Level I Far-End (Rx) Template Intervals .....	47
Table 26:	Level II Short Run Transmitter Output Electrical Specifications.....	49
Table 27:	Level II Medium Run Transmitter Output Electrical Specifications .....	50
Table 28:	Level II Medium Run Near-End (Tx) Template Intervals.....	52
Table 29:	Level II Short Run Receiver Electrical Input Specifications .....	53
Table 30:	Level II MR Receiver Electrical Input Specifications.....	55
Table 31:	Level II Far-End (Rx) Template Intervals .....	56
Table 32:	PCCLKP/N and REFCLKP/NClock Electrical Characteristics .....	57
Table 33:	JTAG and Test Interface AC Specifications .....	59
Table 34:	I2C Interface AC Specifications .....	60
Table 35:	GPIO Interface AC Specifications.....	61
Table 36:	RSTn Signal AC Specifications.....	61
Table 37:	Package Dimensions .....	62
Table 38:	Junction to Ambient Characteristics – Theta JB/JC.....	64
Table 39:	Junction to Ambient Characteristics – Theta JA .....	64



## About this Document

Topics discussed include the following:

- [Overview](#)
- [Document Conventions](#)
- [Revision History](#)

### Overview

The *Tsi721 Datasheet* provides signal, electrical, and packaging information about the Tsi721. It is intended for hardware engineers who are designing system interconnect applications with the device.

### Document Conventions

This document uses the following conventions.

#### Non-differential Signal Notation

Non-differential signals are either active-low or active-high. An active-low signal has an active state of logic 0 (or the lower voltage level), and is denoted by a lowercase "n". An active-high signal has an active state of logic 1 (or the higher voltage level), and is not denoted by a special character. The following table illustrates the non-differential signal naming convention.

State	Single-line signal	Multi-line signal
Active low	NAME <sub>n</sub>	NAME <sub>n</sub> [3]
Active high	NAME	NAME[3]

#### Differential Signal Notation

Differential signals consist of pairs of complement positive and negative signals that are measured at the same time to determine a signal's active or inactive state (they are denoted by "\_p" and "\_n", respectively). The following table illustrates the differential signal naming convention.

State	Single-line signal	Multi-line signal
Inactive	NAME <sub>p</sub> = 0 NAME <sub>n</sub> = 1	NAME <sub>p</sub> [3] = 0 NAME <sub>n</sub> [3] = 1
Active	NAME <sub>p</sub> = 1 NAME <sub>n</sub> = 0	NAME <sub>p</sub> [3] is 1 NAME <sub>n</sub> [3] is 0

### Object Size Notation

- A *byte* is an 8-bit object.
- A PCIe *word* is a 16-bit object.
- A PCIe *doubleword* (DW) is a 32-bit object.
- An S-RIO *word* is a 32-bit object.
- An S-RIO *doubleword* (Dword) is a 64-bit object.

### Numeric Notation

- Hexadecimal numbers are denoted by the prefix *0x* (for example, 0x04).
- Binary numbers are denoted by the prefix *0b* (for example, 0b010).
- Registers that have multiple iterations are denoted by {x..y} in their names; where *x* is first register and address, and *y* is the last register and address. For example, REG{0..1} indicates there are two versions of the register at different addresses: REG0 and REG1.

### Symbols



This symbol indicates important configuration information or suggestions.



This symbol indicates procedures or operating levels that may result in misuse or damage to the device.

## Revision History

April 4, 2016

- Added GCLV, GILH, and GILV part numbers to [Ordering Information](#)

May 5, 2014

- Updated the description of the  $V_{IN\_DIFF}$  parameter in [Table 32](#)

December 3, 2012

- Updated [Ordering Information](#) with production ordering numbers

February 28, 2012

- Added a footnote to [Absolute Maximum Ratings](#), and removed the minimum rating for  $T_{JN}$  from the same section
- Added  $T_{JN}$  and a footnote to [Recommended Operating Conditions](#)

December 16, 2011

- Updated the minimum and maximum values for AVDD10 in [Recommended Operating Conditions](#)
- Added [Power Consumption](#) data
- Changed the Moisture Sensitivity Level to 4



# 1. Device Overview

Topics discussed include the following:

- [Overview](#)
- [Features](#)
- [Block Diagram](#)
- [Typical Applications](#)

## 1.1 Overview

IDT is the leading supplier of RapidIO® and PCI Express Interconnect solutions, providing a broad portfolio of switches, bridges, IP, and development platforms for defense aerospace, video, imaging, and wireless markets. The Tsi721 is IDT's solution for hardware-based PCIe Gen2 to RapidIO Gen2 protocol conversion in a bridging device.

The Tsi721 converts transactions from PCIe to RapidIO, and vice versa, and provides full line rate bridging at 20 Gbaud. Using the Tsi721, designers can develop heterogeneous systems that leverage the peer-to-peer networking performance of RapidIO while using multiprocessor clusters that may be only PCIe enabled. In addition, applications that require large amounts of data transferred efficiently without processor involvement can be executed using the full line rate of the Tsi721's Block DMA Engine and Messaging Engine.

Key to the Tsi721 is the hardware bridging functionality that converts PCIe transactions to RapidIO, and vice versa. The Tsi721 supports PCIe non-transparent bridging for transaction mapping. The device has both RapidIO and PCIe endpoints embedded in the bridge, and each of its Block DMA/Messaging DMA channels can buffer up to 8 KB of data on the PCIe side.

## 1.2 Features

The Tsi721 supports the following features.

### 1.2.1 PCIe Features

- PCIe 2.1 standard compliant
- 5/2.5 Gbaud link speed
- x4/x2/x1 link width
- 128- and 256-byte maximum payload
- Advanced error reporting
- Internal error reporting
- Lane reversal
- Automatic polarity inversion
- Dynamic port width: x4 drops to x1
- ECRC support
- INTx, MSI, and MSI-X support



- Single virtual channel, VC0
- Single traffic class, TC0
  - Generates only PCIe posted/non-posted TLPs with TC0
  - Generates only PCIe Cpl/CplD TLPs with TC matching their requests
  - Accepts PCIe TLPs with any TC
- Four BARs
  - Prefetchable BAR with 32- or 64-bit addressing for PCIe-to-S-RIO bridging
  - Non-prefetchable BAR with 32- or 64-bit addressing for PCIe-to-S-RIO bridging
  - Non-prefetchable BAR with 32-bit addressing for PCIe MWr to S-RIO doorbell bridging
  - Non-prefetchable BAR with 32-bit addressing for Tsi721 internal register access
- Initial credit advertisement programmable through EEPROM
- Dynamic control of credits through registers
- Starvation prevention based on flow control credit updates
- Large buffers
  - 12 KB/2 KB/12 KB input buffers for up to 127 posted/non-posted/completion TLPs
  - 12 KB/2 KB/12 KB output buffers for up to 128 posted/non-posted/completion TLPs
- Debug features
  - Slave analog loopback through a control register
  - Slave loopback using TS1/TS2 ordered sets
  - Master loopback
  - Internal error reporting
  - ECC protection on internal memories

### 1.2.2 S-RIO Features

- S-RIO 2.1 standard compliant
- 5/3.125/2.5/1.25 Gbaud link speed
- x4/x2/x1 link width
- 34-, 50-, and 66-bit addressing
- 16 destID filters
- 8 S-RIO flows
- 9-KB ingress buffer (32 x 288)
- 9-KB egress buffer (32 x 288)
- Lane reversal
- Lane polarity inversion

### 1.2.3 Bridging Features

- Store and forward from PCIe to S-RIO
- Store and forward from S-RIO to PCIe
- Line rate support for 64 byte and larger packets
- 32 outstanding PCIe requests to root complex

- 32 outstanding S-RIO NREAD/maintenance read requests to S-RIO network
- 32 outstanding S-RIO NWRITE\_R/maintenance write/doorbell requests to S-RIO network
- 12-KB completion reassembly buffer
- 8 windows from PCIe to S-RIO with 8 zones (sub windows) per window
- 8 windows from S-RIO to PCIe
- Initiates and receives the following S-RIO transactions:
  - NREAD
  - SWRITE/NWRITE/NWRITE\_R
  - Maintenance read and write
  - Port-write
  - Doorbell
  - Type 8 response
  - Type 13 response
- Initiates and receives the following PCIe transactions:
  - MWr
  - MRd
  - Cpl
  - CplD
- Round-robin scheduling between Mapping Engine, Block DMA Engine, and Messaging traffic to the S-RIO link
- Round-robin scheduling between Mapping Engine, Block DMA Engine, and Messaging traffic to the PCIe link
- Forward bridge
  - Connects PCIe root complex to S-RIO network
  - PCIe Type 0 configuration header

#### 1.2.4 Messaging Features

- 8 Tx queues with one dedicated messaging DMA engine per Tx queue
- 8 Rx queues with one dedicated messaging DMA engine per Rx queue
- Descriptor prefetch per Tx queue
- 32 outstanding PCIe requests to root complex
- 8-KB message segment reassembly buffer per Tx queue
- Round-robin scheduling among Tx queues
- One outstanding message per Tx queue
- 16 receive contexts per Rx queue

#### 1.2.5 Block DMA Engine Features

- 8 DMA channels
- Each DMA channel can perform DMA writes from root complex to S-RIO network, or DMA reads from S-RIO network to root complex
  - DMA from PCIe port to PCIe port is not supported
  - DMA from S-RIO port to S-RIO port is not supported

- Round-robin scheduling among DMA channels
- DMA descriptors for all channels reside on PCIe side
- Scatter-and-gather with descriptor list
- Supports DMA strides
- Supports up to 64 MB data for a single descriptor
- Supports both read and write descriptors per DMA channel
- Dynamic descriptor chaining
- Flexible addressing modes
  - Linear addressing
  - Constant addressing
- Descriptor prefetch
- 32 outstanding PCIe requests to root complex
- 64 outstanding S-RIO NREAD/maintenance read requests to S-RIO network
- 64 outstanding S-RIO NWRITE\_R/maintenance write requests to S-RIO network
- Supports the following S-RIO transactions:
  - NREAD
  - NWRITE
  - SWRITE
  - NWRITE\_R
  - Maintenance read
  - Maintenance write

#### 1.2.6 Miscellaneous Features

- I<sup>2</sup>C interface supports the following:
  - As a slave, being read/written by an external master during normal operations
  - As a master, reading external EEPROM during boot load
  - As a master, reading/writing other external devices during normal operations
- JTAG 1149.1, 1149.6 (AC JTAG)
- 16 GPIO pins

### 1.3 Block Diagram

The Tsi721 block diagram is displayed in the following figure. The five main functions of the device are briefly described below.

Figure 1: Block Diagram

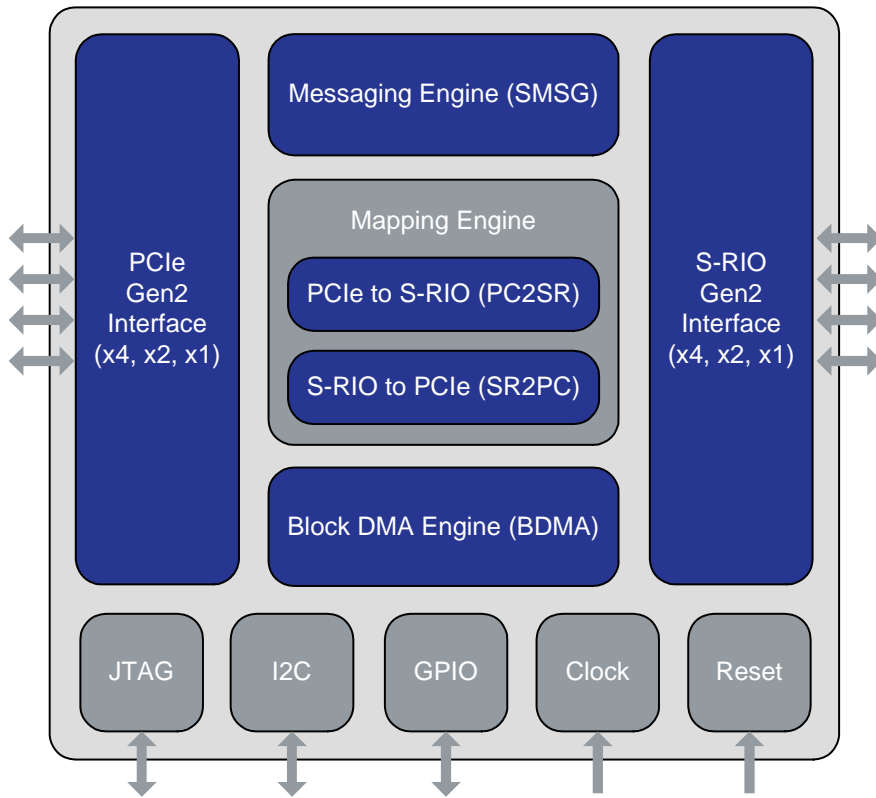

#### 1.3.1 PCIe Interface

The PCIe Interface performs all the physical, data link, and transport layer protocols associated with PCIe.

#### 1.3.2 S-RIO Interface

The S-RIO Interface performs all the physical and transport layer protocols associated with S-RIO.

#### 1.3.3 Messaging Engine

The Messaging Engine uses S-RIO messaging logical layer functions with dedicated messaging DMA channels per Tx queue and per Rx queue.

#### 1.3.4 Mapping Engine

The Mapping Engine maps between PCIe and S-RIO transactions, including segmentation and reassembly as required.

#### 1.3.5 Block DMA Engine

The Block DMA Engine uses 8 DMA channels, where descriptors of each DMA channel can perform read or write.

## 1.4 Typical Applications

The Tsi721 supports the following typical applications:

- Defense and aerospace
  - Radar
  - Sonar
  - Navigations systems
- Medical imaging
  - CT scanners
  - MRIs
- Video
  - Teleconferencing
  - Head end
- Wireless
  - Baseband cards with x86

Three of Tsi721's typical applications – defense/aerospace, video/imaging, and wireless – are discussed in the following sections.

### 1.4.1 Defense/Aerospace Application

In defense applications, the Tsi721 supports the use of PCIe enabled x86 processors to RapidIO backplanes. This provides system designers with the best of both worlds: the floating point and MIPS horsepower of the latest generation of x86 solutions, with the superior peer-to-peer networking performance of RapidIO architectures.

By using the Tsi721 combined with IDT's RapidIO Gen2 switches, payload processor cards with x86 processors can be used with existing RapidIO 1.3 backplanes operating at up to 3.125 Gbaud, or the same card can be used with RapidIO Gen2 compatible backplanes operating at 5 Gbaud.

Figure 2: Defense/Aerospace Application

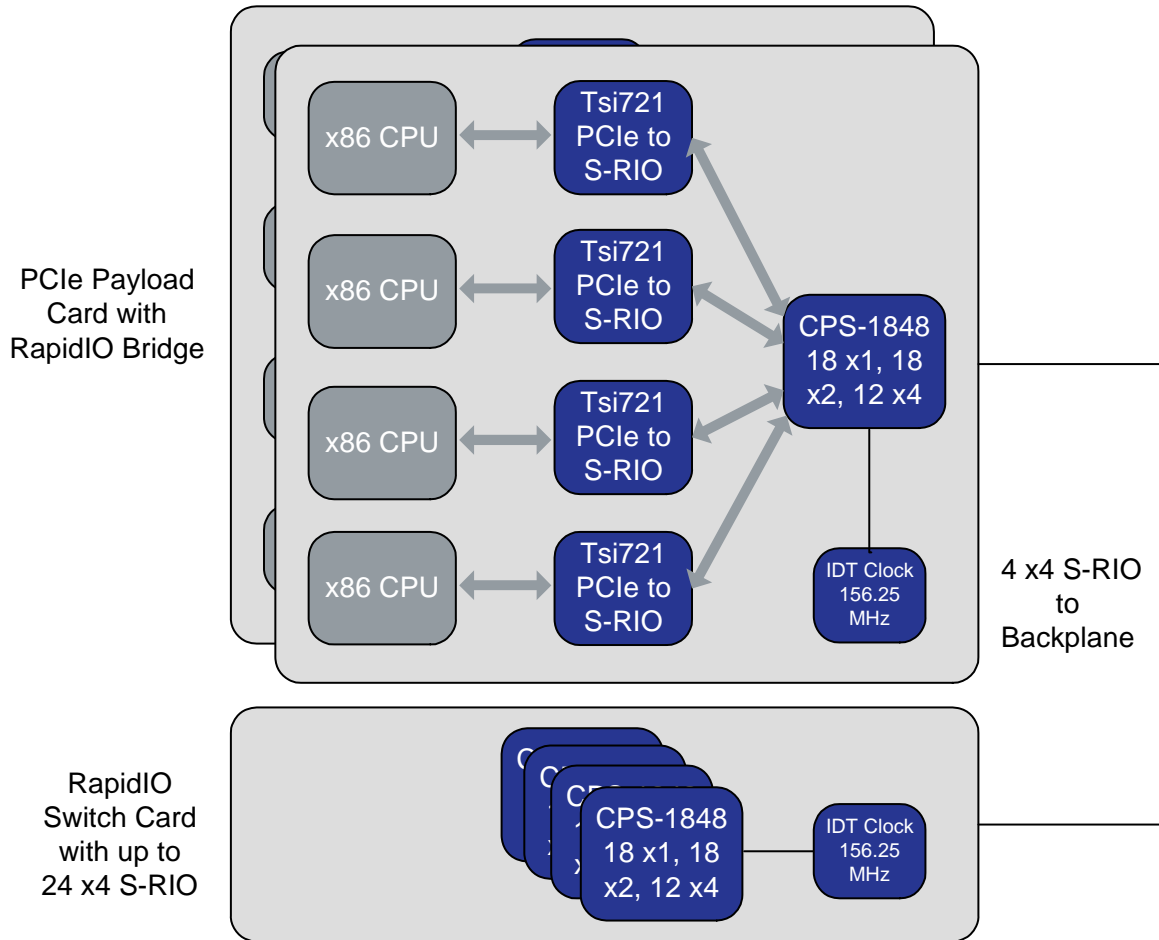

### 1.4.2 Video and Imaging Application

In video and imaging applications, system designers need to cluster large numbers of DSPs or FPGAs to perform encoding/decoding/trans coding, or do FFTs (Fast Fourier Transform) on large arrays of data. The RapidIO protocol is optimal for this DSP/FPGA cluster requirement. However, the analog front-end to the system is usually a sensor with streaming data terminated in an FPGA (for example, a camera subsystem). This is usually in a PCIe network, often with a PC back-end. In these applications the designer needs to bridge between a PCIe network and the RapidIO DSP/FPGA cluster. The Tsi721 is ideal for this application.

Figure 3: Video and Imaging Application

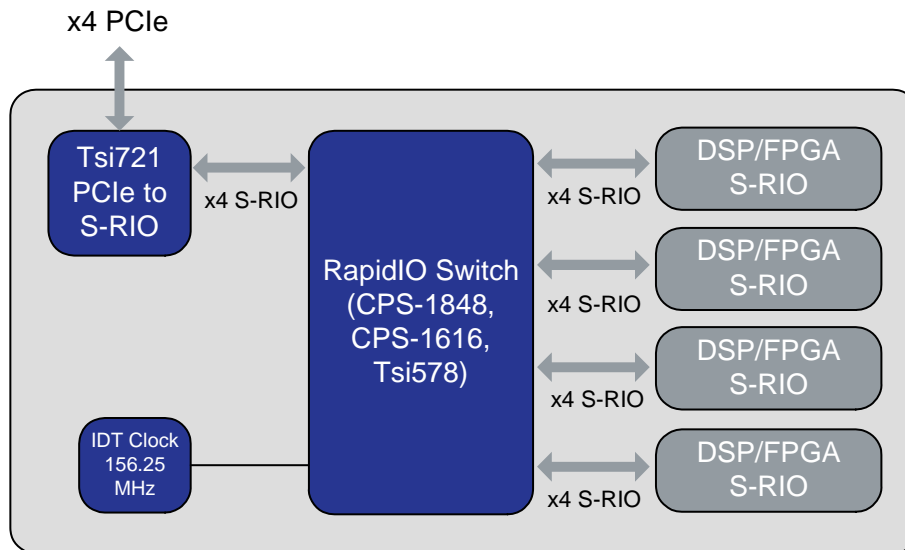

### 1.4.3 Wireless Application

In wireless base stations, the incumbent interconnect technology in the baseband processing cards – LTE, WiMAX, WCDMA, and TD-SCDMA – is RapidIO. RapidIO connects a cluster of DSPs, processor, and FPGA, locally on the baseband processor for MAC and PHY layer processing. However, the LTE standard pushes the performance available in existing RapidIO enabled microprocessors.

The Tsi721 provides wireless OEMs with an additional option to use an x86 processor with superior MIPs in a baseband card that is predominantly RapidIO. In these card designs, RapidIO is the interconnect between devices and functions as the backplane interconnect. x86 processors can now be used with other RapidIO devices on the baseband card and leverage the messaging performance of RapidIO for this peer-to-peer multiprocessor network.

Figure 4: Wireless Application

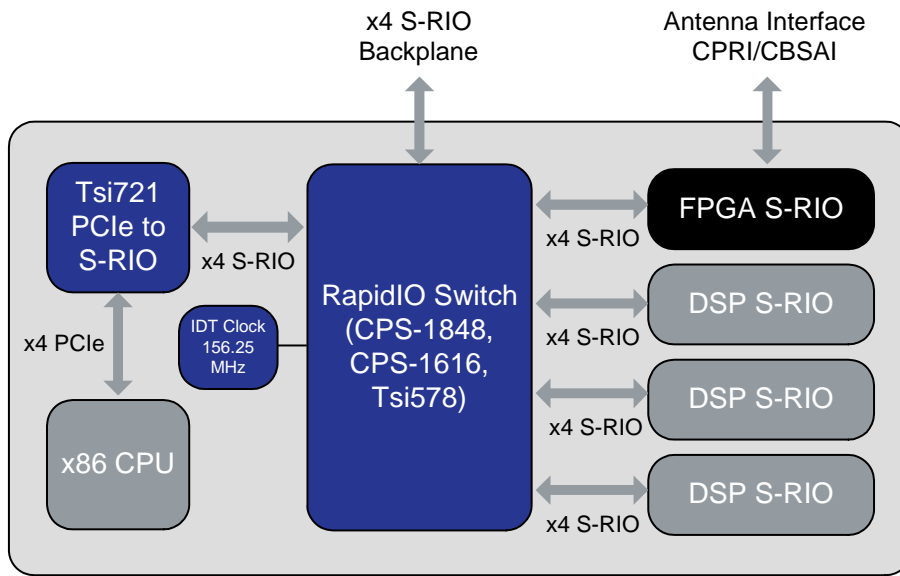





## 2. Signals

Topics discussed include the following:

- [Overview](#)
- [Ballmap](#)
- [Pinlist](#)
- [PCIe Signals](#)
- [S-RIO Signals](#)
- [General Signals](#)
- [I2C Signals](#)
- [JTAG and Test Interface Signals](#)
- [GPIO Signals](#)
- [Power-up Signals](#)
- [Power Supply Signals](#)

### 2.1 Overview

The following conventions are used in this chapter:

- Signals with the suffix "P" are the positive half of a differential pair.
- Signals with the suffix "N" are the negative half of a differential pair.
- Signals with the suffix "n" are active low.

Signals are classified according to the types defined in the following table.

Table 1: Signal Types

Pin Type	Definition
I	3.3/2.5V LVTTTL Input
O	3.3/2.5V LVTTTL Output
IO	3.3/2.5V LVTTTL Bidirectional
IO-OD	3.3/2.5V LVTTTL Bidirectional Open Drain
OD	3.3/2.5V LVTTTL Open Drain
I-PU	3.3/2.5V LVTTTL Input with Pull-up
I-PD	3.3/2.5V LVTTTL Input with Pull-down

Table 1: Signal Types (Continued)

Pin Type	Definition
IO-PD	3.3/2.5V LVTTTL Bidirectional with Pull-down
IO-PU	3.3/2.5V LVTTTL Bidirectional with Pull-up
PCIE_O	Differential CML PCIe output
PCIE_I	Differential CML PCIe input
SRIO_O	Differential CML S-RIO output
SRIO_I	Differential CML S-RIO input
DIFF_I	Differential CML input
PWR	Power
GND	Ground

## 2.2 Ballmap

Figure 5: Ballmap

	1	2	3	4	5	6	7	8	9	10	11	12
A	NO BALL	GPIO[9]	VSS	PCRP[0]	PCTP[0]	PCTP[1]	PCRP[1]	PCRP[2]	PCTP[2]	PCTP[3]	PCRP[3]	PCCLKP
B	GPIO[0]	GPIO[10]	VSS	PCRN[0]	PCTN[0]	PCTN[1]	PCRN[1]	PCRN[2]	PCTN[2]	PCTN[3]	PCRN[3]	PCCLKN
C	GPIO[1]	GPIO[11]	VSS	VSS	AVDD25	AVDD25	AVDD25	AVDD25	VSS	VSS	VSS	PCBIAS
D	GPIO[2]	GPIO[12]	VDDIO	AVTT	AVTT	VSS	VSS	AVDD10	AVDD10	VSS	TDO	PCRSTOn
E	GPIO[3]	GPIO[13]	VDDIO	AVTT	VDD	VSS	VSS	VDD	AVDD10	VDDIO	TCK	TEST_BCE
F	GPIO[4]	GPIO[14]	VDDIO	AVTT	VSS	VDD	VDD	VSS	AVDD10	VDDIO	TDI	TEST_ON
G	GPIO[5]	GPIO[15]	VDDIO	AVTT	VSS	VDD	VDD	VSS	AVDD10	VDDIO	VSS	TEST_BIDIR_CTL
H	GPIO[6]	STRAP_RATE[0]	VDDIO	AVTT	VDD	VSS	VSS	VDD	AVDD10	VDDIO	TMS	RSTn
J	GPIO[7]	STRAP_RATE[1]	VDDIO	AVTT	AVTT	VSS	VSS	AVDD10	AVDD10	VSS	TRSTn	SRRSTOn
K	GPIO[8]	STRAP_RATE[2]	VSS	VSS	AVDD25	AVDD25	AVDD25	AVDD25	VSS	VSS	VSS	SRBIAS
L	I2C_SCL	CLKMOD	VSS	SRRN[0]	SRTN[0]	SRTN[1]	SRRN[1]	SRRN[2]	SRTN[2]	SRTN[3]	SRRN[3]	REFCLKN
M	I2C_SDA	MECS	SR_BOOT	SRRP[0]	SRTP[0]	SRTP[1]	SRRP[1]	SRRP[2]	SRTP[2]	SRTP[3]	SRRP[3]	REFCLKP

## 2.3 Pinlist

For a list-based version of Tsi721's pin to signal mapping, see the *Tsi721 Ballmap and Pinlist*.

## 2.4 PCIe Signals

Table 2: PCIe Signals

Name	Pin Type	Description
PCTP[3:0] PCTN[3:0]	PCIE_O	Differential transmit data for the PCIe port.
PCRP[3:0] PCRN[3:0]	PCIE_I	Differential receive data for the PCIe port.
PCCLKP PCCLKN	DIFF_I	PCIe reference clock input. When in PCIe common clock mode (CLKMOD pin is high, see the "Clocking" chapter in the Tsi721 User Manual), PCCLKP/N requires a clock frequency of 100 MHz. When in PCIe non-common clock mode (CLKMOD pin is low), PCCLKP/N requires a clock frequency as selected by CLKSEL[1:0], and must have the same clock frequency as REFCLKP/N.
PCRSTOn	IO	It is an output for normal operation and an input during scan test mode. As an asynchronous active-low reset output, this pin is low when the following occurs: <ul style="list-style-type: none"> <li>• The PCIe port detects hot reset</li> <li>• The PCIe port is DL_DOWN</li> </ul>

## 2.5 S-RIO Signals

Table 3: S-RIO Signals

Name	Pin Type	Description <sup>a</sup>
S RTP[3:0] S RTN[3:0]	S RIO_O	Differential transmit data for the S-RIO port.
S RRP[3:0] S RRN[3:0]	S RIO_I	Differential receive data for the S-RIO port.
S RRSTOn	IO	It is an output for normal operation and an input during scan test mode. As an asynchronous active-low reset output, this pin is low when four consecutive S-RIO reset symbols are received, and SELF_RST is set to 1 in the RapidIO PLM Port Implementation Specific Control Register
MECS	IO-PD	Asynchronous S-RIO Multicast Event Control Symbol (MECS). Its direction is controlled by the MECS_O bit in the Device Control Register. As an <i>input</i> , a rising or falling edge triggers an S-RIO MECS to be sent on the S-RIO link. Use the RIO_PLM_SPO_MECS_FWD.SUBSCRIPTION/MULT_CS and RIO_EM_MECS_TRIG_EN.CMD_EN to select the CMD field that should be set with the MECS. Multiple MECSs with different CMD fields can be generated by setting these fields appropriately. As an <i>output</i> , this signal is toggled when an S-RIO MECS is received. Only a single MECS CMD value should be selected to toggle the MECS input. Set the RIO_EM_MECS_CAP_EN.CMD_EN to select the CMD value to be propagated to the MECS pin. Note: Only 1 bit should be enabled in CMD_EN.

a. For information on S-RIO signals that are used for power-up purposes only, see [Power-up Signals](#).

## 2.6 General Signals

Table 4: General Signals

Name	Pin Type	Description
RSTn	I-PU	Fundamental reset (device reset). Assertion of this signal resets all logic inside the Tsi721.
REFCLKP REFCLKN	DIFF_I	S-RIO reference clock input. REFCLK requires a clock frequency as selected by CLKSEL[1:0].

## 2.7 I2C Signals

The I2C Interface is used for the following:

- As a master, downloading configuration from EEPROM
- As a master, allowing the PCIe root complex or the S-RIO host to configure other I2C expansion devices
- As a slave, exposing internal register space to an I2C master (Note: To be used for lab debug or another master-driven initialization).

Table 5: I<sup>2</sup>C Signals

Name	Pin Type	Description <sup>a</sup>
I2C_SCL	IO-OD	Serial clock for the I2C Interface with a maximum frequency of 100 kHz.
I2C_SDA	IO-OD	Serial data for the I2C Interface.

a. For information on I2C signals that are used for power-up purposes only, see [Power-up Signals](#).

## 2.8 JTAG and Test Interface Signals

Table 6: JTAG Interface Signals

Name	Pin Type	Description
TCK	I-PD	IEEE 1149.1/1149.6 test access port. Clock input.
TDI	I-PU	IEEE 1149.1/1149.6 test access port. Serial data input
TDO	O	IEEE 1149.1/1149.6 test access port. Serial data output
TMS	I-PU	IEEE 1149.1/1149.6 test access port. Test mode select
TRSTn	I-PU	IEEE 1149.1/1149.6 test access port. Reset input. This input must be asserted during the assertion of RSTn. Thereafter, it can be left in either state.
TEST_ON	I-PD	Test mode pin. Tie low or NC for normal operation.
TEST_BCE	I-PU	Boundary scan compatibility enabled pin. This input aids 1149.6 testing. It must be tied to VDDIO (or NC as there is internal pull up in pad) during normal operation of the device.  0 = JTAG chain includes SerDes registers. SerDes registers are accessible to external JTAG pins. Used during ATE and lab debug of SerDes registers through an external JTAG Controller.  1 = JTAG chain does not include SerDes registers. SerDes register are accessible through the internal register bus for BAR 0 access.
TEST_BIDIR_CTL	I-PU	Test mode pin. Tie high or NC for normal operation.

## 2.9 GPIO Signals

Table 7: GPIO Signals

Name	Pin Type	Description
GPIO[15:0]	IO	<p>Asynchronous general purpose I/O.</p> <ul style="list-style-type: none"> <li>Each GPIO pin can be configured as a general purpose I/O pin.</li> <li>Each pin can be configured as either an input or an output</li> <li>When configured as an output, GPIO[0] is asserted high when BDMA/SMSG/PC2SR/SR2PC has an uncorrectable ECC error or S-RIO MAC has a non-data memory uncorrectable ECC error</li> <li>When configured as an output, GPIO[1] is asserted high when Tsi721 PCIe port is not in the data link active state</li> <li>When configured as an output, GPIO[2] is asserted high when Tsi721 has an active interrupt (for more information, see <a href="#">Figure 18</a> and <a href="#">Figure 19</a>)</li> <li>When configured as an output, GPIO[15:3] can be programmed through software</li> </ul> <p>GPIO[12:0] are used as power-up pins as displayed in <a href="#">Table 8</a>. These signals must remain stable for 4000 REFCLKP/REFCLKN cycles after RSTn is de-asserted. They are ignored after reset.</p>

Table 8: GPIO Mapping to Power-up Signals

GPIO Pin Name (Primary Function)	Power-up Pin Name <sup>a</sup> (Secondary Function)
GPIO[3:0]	I2C_SA[3:0]
GPIO[4]	I2C_DISABLE
GPIO[5]	I2C_SEL
GPIO[6]	I2C_MA
GPIO[7]	SP_SWAP_RX
GPIO[8]	SP_SWAP_TX
GPIO[9]	SP_HOST
GPIO[10]	SP_DEVID
GPIO[12:11]	CLKSEL[1:0]

a. For more information about these signals, see [Power-up Signals](#).

## 2.10 Power-up Signals

Table 9: Power-Up Signals

Name	Pin Type	Description
CLKMOD	I-PU	Clock mode. When high, Tsi721 uses "PCIe common clocked mode." When low, it uses "PCIe non-common clocked mode." It is a static signal.
CLKSEL[1:0]	IO	REFCLKP/REFCLKN clock frequency select; PCCLKP/PCCLKN clock frequency select when in PCIe non-common clock mode. <ul style="list-style-type: none"> <li>• 0b11 = 125 MHz</li> <li>• 0b10 = 100 MHz</li> <li>• 0b01 = 156.25 MHz</li> <li>• Others = Reserved</li> </ul> When a 100-MHz clock is used, S-RIO SerDes rates of 1.25/2.5/5 Gbaud are supported. When a 125/156.25-MHz clock is used, S-RIO SerDes rates of 1.25/2.5/3.125/5 Gbaud are supported. When either a 100/125/156.25-MHz clock is used, PCIe SerDes rates of 2.5/5 Gbaud are supported. These power-up signals are multiplexed with GPIO[12:11]. It is a static signal.
I2C_DISABLE	IO	Disable I <sup>2</sup> C register loading after reset. When asserted, Tsi721 does not attempt to load register values from an EEPROM over the I <sup>2</sup> C bus. <ul style="list-style-type: none"> <li>0 = Enable boot load from EEPROM</li> <li>1 = Disable boot load from EEPROM</li> </ul> This power-up signal is multiplexed with GPIO[4]. It is a static signal.
I2C_MA	IO	I <sup>2</sup> C multi-byte address mode. If I2C_DISABLE == 0 (that is, download registers from EEPROM) then: <ul style="list-style-type: none"> <li>0 = Tsi721 uses 1-byte addressing for EEPROM</li> <li>1 = Tsi721 uses 2-byte addressing for EEPROM</li> </ul> Else I2C_DISABLE == 1 (do not download from EEPROM) <ul style="list-style-type: none"> <li>• 0 = Tsi721 is boot loaded by the PCIe root complex after reset</li> <li>• 1 = Tsi721 is boot loaded by an external I2C master after reset</li> </ul> This power-up signal is multiplexed with GPIO[6]. It is a static signal.
I2C_SA[3:0]	IO	I2C slave address. The values on these pins represent the values for the 7-bit address of the Tsi721 when acting as an I <sup>2</sup> C slave. These signals, in combination with the I2C_SEL signal, determine the address of the EEPROM to boot from (see I2C_SEL pin description). The values on these pins can be overridden after a reset by writing to the I2C Slave Configuration Register. These power-up signals are multiplexed with GPIO[3:0]. It is a static signal.

Table 9: Power-Up Signals (Continued)

Name	Pin Type	Description
I2C_SEL	IO	<p>I<sup>2</sup>C pin select. Combined with the I2C_SA[1,0] pins, Tsi721 will determine the lower 2 bits of the 7-bit address of the EEPROM address it boots from.</p> <p>When asserted, the I2C_SA[1:0] pins represent the two LSBs of the 7-bit EEPROM slave address when Tsi721 acts as a I<sup>2</sup>C master downloading from an EEPROM. The EEPROM slave address is as follows:</p> <p>A6 = 1  A5 = 0  A4 = 1  A3 = 0  A2 = 0  A1 = I2C_SA[1]  A0 = I2C_SA[0]</p> <p>When de-asserted, the I2C_SA[1:0] pins are ignored and the lower two bits of the EEPROM address default to 00. The values of the EEPROM address can be overridden by software after initialization.</p> <p>This power-up signal is multiplexed with GPIO[5]. It is a static signal.</p>
SP_DEVID	IO	<p>S-RIO base deviceID control</p> <p>When the SP_HOST pin is high, it configures the reset value of the RapidIO Base deviceID CSR: the LSB of the CSR's BASE_ID and LAR_BASE_ID fields are set to SP_DEVID, while other bits of these fields are set to 0.</p> <p>When the SP_HOST pin is low and SP_DEVID is high, it configures the reset value of the RapidIO Base deviceID CSR: the CSR's BASE_ID and LAR_BASE_ID fields are set to all ones.</p> <p>When the SP_HOST pin is low and SP_DEVID is low, it configures the reset value of the RapidIO Base deviceID CSR: the CSR's BASE_ID field is set to 0xFE and the CSR's LAR_BASE_ID field are set to 0x00FE.</p> <p>This signal is multiplexed with GPIO[10]. It is a static signal.</p>
SP_HOST	IO	<p>S-RIO host / slave control. This signal sets the reset value of the HOST bit of the RapidIO Port General Control CSR.</p> <p>0 = Tsi721 is an S-RIO slave.  1 = Tsi721 is an S-RIO host.</p> <p>This signal is multiplexed with GPIO[9]. It is a static signal.</p>
SP_SWAP_RX	IO	<p>S-RIO receive lane swap. This signal sets the reset value of the SWAP_RX[1:0] bits of RapidIO PLM Port Implementation Specific Control Register.</p> <p>0 = Disable S-RIO port receive lane swap; that is, set the SWAP_RX[1:0] register bits to 0b00.  1 = Enable S-RIO port receive 4x lane swap; that is, set the SWAP_RX[1:0] register bits to 0b10.</p> <p>This signal is multiplexed with GPIO[7].</p>



Table 9: Power-Up Signals (Continued)

Name	Pin Type	Description
SP_SWAP_TX	IO	S-RIO transmit lane swap. This signal sets the reset value of the SWAP_TX bit of RapidIO PLM Port Implementation Specific Control Register. 0 = Disable S-RIO port transmit lane swap. 1 = Enable S-RIO port transmit lane swap. This signal is multiplexed with GPIO[8]. It is a static signal.
SR_BOOT	I-PD	Boot from S-RIO. It can be asserted high only when I2C_DISABLE is also high. 1 = The Tsi721 S-RIO link can start training immediately after a fundamental reset and Tsi721 automatically sets the SRBOOT_CMPL bit of Device Control Register. 0 = The Tsi721 S-RIO link can start training only after software sets the SRBOOT_CMPL bit. It is a static signal.
STRAP_RATE[2:0]	I-PU	S-RIO link rate. These signals control the reset value of the BAUD_SEL field of the RapidIO Port Control 2 CSR . Note that the BAUD_SEL encoding is different than that of STRAP_RATE. <ul style="list-style-type: none"> <li>• 0b111 = 5 Gbaud</li> <li>• 0b110 = 2.5 Gbaud</li> <li>• 0b101 = 1.25 Gbaud</li> <li>• 0b010 = 3.125 Gbaud</li> <li>• Others: Reserved</li> </ul> It is a static signal.

## 2.11 Power Supply Signals

Table 10: Power Supply Signals

Name	Pin Type	Description
VDD	PWR	1.0V core power
VDDIO	PWR	3.3/2.5V power for LVTTTL IO
AVDD10	PWR	1.0V PCIe and S-RIO SerDes analog power supply
AVDD25	PWR	2.5V PCIe and S-RIO SerDes analog power supply
AVTT	PWR	1.5V PCIe and S-RIO SerDes transmitter analog voltage
VSS	GND	Shared digital and analog ground
PCBIAS	IO	Reference for the corresponding PCIe SerDes bias currents and PLL calibration circuitry. A 200 Ohm 1% 100ppm/C precision resistor should be connected from this pin to ground and isolated from any source of noise injection.
SRBIAS	IO	Reference for the corresponding S-RIO SerDes bias currents and PLL calibration circuitry. A 200 Ohm 1% 100ppm/C precision resistor should be connected from this pin to ground and isolated from any source of noise injection.



### 3. Electrical Characteristics

Topics discussed include the following:

- [Absolute Maximum Ratings](#)
- [Recommended Operating Conditions](#)
- [Power Consumption](#)
- [Power Supply Sequencing](#)
- [DC Operating Characteristics](#)
- [Decoupling Recommendation](#)
- [AC Timing Specifications](#)

#### 3.1 Absolute Maximum Ratings

Table 11: Absolute Maximum Ratings<sup>a</sup>

Symbol	Parameter	Minimum	Maximum	Units
VDDIO	3.3/2.5V I/O voltage with respect to VSS	-0.5	3.6	V
VDD	1.0V core voltage with respect to VSS	-0.5	1.10	V
AVDD10	1.0V analog voltage with respect to AVSS	-0.5	1.10	V
AVDD25	2.5V analog voltage with respect to AVSS	-0.5	2.75	V
AVTT	1.5V analog voltage for SerDes transmitter with respect to AVSS	-0.5	2.75	V
T <sub>BIAS</sub>	Temperature under bias	-40	125	C
T <sub>STG</sub>	Storage temperature	-65	150	C
T <sub>JN</sub>	Junction temperature	-	125	C
I <sub>OUT</sub> (for VDDIO = 3.3/2.5V)	DC output current	-	30	mA

a. Stresses outside the absolute ratings can cause permanent damage to the device and affect its functional performance. Exposure to absolute rating conditions for extended periods can affect reliability.

### 3.2 Recommended Operating Conditions

Table 12: Recommended Operating Conditions<sup>a</sup>

Symbol	Parameter	Minimum	Maximum	Units
T <sub>A</sub>	Ambient temperature – Commercial	0	70	°C
	Ambient temperature – Industrial	-40	85	°C
T <sub>JN</sub>	Junction temperature	-	110	°C
VDDIO	3.3V LVTTTL I/O supply voltage	3.14	3.47	V
	2.5V LVTTTL I/O supply voltage	2.4	2.6	V
VDD	1.0V Core supply voltage	0.95	1.05	V
AVDD10	1.0V SerDes analog supply voltage	0.95	1.05	V
AVDD25	2.5V SerDes analog supply voltage	2.25	2.75	V
AVTT	1.5V SerDes transmitter analog supply voltage	1.4	1.7	V

a. Exposure to conditions outside the recommended operating conditions can affect the operation and/or reliability of the device.

### 3.3 Power Consumption

Table 13 lists the current draw for each supply group for different environmental conditions. Test characteristics were as follows:

- RapidIO and PCIe links configured at operated at 5 Gbps in x4 mode
- Traffic passed through the Tsi721 with a high incidence of 0/1 toggling
- Power measurements are based on worst case fast silicon processing. A “Total Power” reduction in excess of 5% can be expected for nominal/typical silicon.

Table 13: Power Consumption

Junction Temp (°C)	Voltage	VDD		AVDD10		AVDD25		AVTT		VDDIO		Total Power (W)
		Voltage (V)	Current [mA]	Voltage (V)	Current [mA]	Voltage (V)	Current [mA]	Voltage (V)	Current [mA]	Voltage (V)	Current [mA]	
125	Max.	1.05	3000	1.05	330	2.75	165	1.70	350	3.47	20	4.61
	Typ.	1.00	2722	1.00	281	2.50	153	1.50	335	3.30	18	3.95
	Min.	0.95	2458	0.95	242	2.25	144	1.40	320	3.14	17	3.39
25	Max.	1.05	1110	1.05	214	2.75	161	1.70	350	3.47	20	2.50
	Typ.	1.00	1003	1.00	190	2.50	151	1.50	335	3.30	18	2.13
	Min.	0.95	909	0.95	170	2.25	142	1.40	320	3.14	17	1.85

Table 13: Power Consumption (Continued)

Junction Temp (°C)	Voltage	VDD		AVDD10		AVDD25		AVTT		VDDIO		Total Power (W)
		Voltage (V)	Current [mA]	Voltage (V)	Current [mA]	Voltage (V)	Current [mA]	Voltage (V)	Current [mA]	Voltage (V)	Current [mA]	
-40	Max.	1.05	829	1.05	192	2.75	159	1.70	350	3.47	20	2.17
	Typ.	1.00	765	1.00	175	2.50	149	1.50	335	3.30	18	1.87
	Min.	0.95	707	0.95	159	2.25	141	1.40	320	3.14	17	1.64

### 3.4 Power Supply Sequencing

This section contains power-up and power-down supply sequencing for the Tsi721.

#### 3.4.1 Power-Up Sequencing

The Tsi721 must have its supplies powered up as follows:

- VDD and AVDD10 (1.0V) must be powered up together.  
To achieve this requirement AVDD10 can be supplied from the same regulator as VDD, but must be isolated on the board through a ferrite bead.
- VDDIO, AVDD25, AVTT, and the 1.0V supplies (VDD and AVDD10) can be powered up in any order.
- The voltages on any input or I/O pin cannot exceed its corresponding supply voltage during power supply ramp up.
- The power supply ramp rates must be kept between 10 V/s and 0.5x10E6 V/s to minimize power current spikes during power up. This leads to the ramp times specified in the following table.

Table 14: Power Supply Sequencing Ramp Times

V	V/s	
	10	5.00E+05
3.3	330000 us	6.6 us
2.5	250000 us	5 us
1.5	150000 us	3 us
1	100000 us	2 us

#### 3.4.2 Power-Down Sequencing

The Tsi721 must have its supplies powered down as follows:

- VDD and AVDD10 (1.0V) must be powered down together. To achieve this requirement AVDD10 can be supplied from the same regulator as VDD, but must be isolated on the board through a ferrite bead.
- VDDIO, AVDD25, AVTT, and the 1.0V supplies (VDD and AVDD10) can be powered down in any order.

### 3.5 DC Operating Characteristics

The following table lists the DC operating characteristics for 3.3V LVTTL of the Tsi721.

**Table 15: 3.3V LVTTL DC Operating Characteristics at Recommended Operating Condition of 3.3V**

Symbol	Parameter	Minimum	Maximum	Units
$V_{IH}$	LVTTL input high voltage	2.0	3.6	V
$V_{IL}$	LVTTL input low voltage	-0.3	0.8	V
$V_{OH}$	LVTTL output high voltage	2.4	-	V
$V_{OL}$	LVTTL output low voltage	-	0.4	V
R pull-up	Resistor pull-up	26K	64K	Ohm
R pull-down	Resistor pull-down	29K	79K	Ohm
$C_{PAD}$	LVTTL pad capacitance	-	4	pF

The following table lists the DC operating characteristics for 2.5V LVTTL of the Tsi721.

**Table 16: 2.5V LVTTL DC Operating Characteristics at Recommended Operating Condition of 2.5V**

Symbol	Parameter	Minimum	Maximum	Units
$V_{IH}$	LVTTL input high voltage	1.7	3.6	V
$V_{IL}$	LVTTL input low voltage	-0.3	0.7	V
$V_{OH}$	LVTTL output high voltage	1.7	-	V
$V_{OL}$	LVTTL output low voltage	-	0.7	V
R pull-up	Resistor pull-up	33K	93K	Ohm
R pull-down	Resistor pull-down	34K	108K	Ohm
$C_{PAD}$	LVTTL pad capacitance	-	4	pF

### 3.6 Decoupling Recommendation

Table 17 provides the recommended decoupling for the Tsi721. Use low ESR, low lead inductance ceramic capacitors with X7R or X5R rating.

Table 17: Decoupling Recommendation

Rail	Decoupling
VDDIO	5x 0.1uF and 1x 10uF
AVTT	5x 0.1uF and 1x 10uF
VDD	5x 0.1uF and 1x 10uF
AVDD10	5x 0.1uF and 1x 10uF
AVDD25	5x 0.1uF and 1x10uF

### 3.7 AC Timing Specifications

This section describes the AC timing specifications and electrical characteristics for the Tsi721.

#### 3.7.1 PCIe Differential Receiver Specifications

Table 18 lists the electrical characteristics for the PCIe differential receivers in the Tsi721. Parameters are defined separately for 2.5 Gbps and 5.0 Gbps implementations. Table 18 is duplicated from the *PCI Express Base Specification (Rev. 2.1)* Section 4.3.3.4 Table 4-12 on page 270.

Table 18: PCIe Differential Receiver Specifications

Symbol	Parameter	2.5 Gbps		5.0 Gbps		Unit	Notes
		Min.	Max.	Min.	Max.		
UI	Unit interval	399.88	400.12	199.94	200.06	ps	UI does not account for SSC caused variations
$V_{RX-DIFF-PP-CC}$	Differential Rx peak-peak voltage	0.175	1.2	0.120	1.2	V	See section 4.3.7.2.2 of the <i>PCI Express Base Specification (Rev. 2.1)</i>
$V_{RX-DIFF-PP-DC}$	Differential Rx peak-peak voltage for data clocked Rx architecture	0.175	1.2	0.100	1.2	V	See section 4.3.7.2.2 of the <i>PCI Express Base Specification (Rev. 2.1)</i>
$T_{RX-EYE}$	Receiver eye time opening	0.40	-	N/A	-	UI	Minimum eye time at Rx pins to produce a $10^{-12}$ BER. See Note 1.
$T_{RX-TJ-CC}$	Maximum Rx inherent timing error	N/A	-	-	0.40	UI	Maximum Rx inherent total timing error for common Refclk Rx architecture. See Note 2.
$T_{RX-TJ-DC}$	Maximum Rx inherent timing error	N/A	-	-	0.34	UI	Maximum Rx inherent total timing error for data clocked Rx architecture. See Note 2.

**Table 18: PCIe Differential Receiver Specifications (Continued)**

Symbol	Parameter	2.5 Gbps		5.0 Gbps		Unit	Notes
		Min.	Max.	Min.	Max.		
$T_{RX-DJ-DD-CC}$	Maximum Rx inherent deterministic timing error	N/A	-	-	0.30	UI	Maximum Rx inherent deterministic timing error for common Refclk Rx architecture. See Note 2.
$T_{RX-DJ-DD-DC}$	Maximum Rx inherent deterministic timing error	N/A	-	-	0.24	UI	Maximum Rx inherent deterministic timing error for data clocked Rx architecture. See Note 2.
$T_{RX-EYE-MEDIAN-to-MAX-JITTER}$	Maximum time delta between median and deviation from median	-	0.3	Not specified		UI	Only specified for 2.5 Gbps
$T_{RX-MIN-PULSE}$	Minimum width pulse at Rx	Not specified		0.6	-	UI	Measured to account for worst Tj at $10^{-12}$ BER. See Figure 4-29 of <i>PCI Express Base Specification (Rev. 2.1)</i>
$V_{RX-MAX-MIN-RATIO}$	Minimum/Maximum pulse voltage on consecutive UI	Not specified		-	5	--	Rx eye must simultaneously meet $V_{RX-EYE}$ limits.
$BW_{RX-PLL-HI}$	Maximum Rx PLL bandwidth	-	22	-	16	MHz	Second order PLL jitter transfer bounding function. See Note 3.
$BW_{RX-PLL-LO-3dB}$	Minimum Rx PLL BW for 3 dB peaking	1.5	-	8	-	MHz	Second order PLL jitter transfer bounding function. See Note 3.
$BW_{RX-PLL-LO-1dB}$	Minimum Rx PLL BW for 1dB peaking	Not specified		5	-	MHz	Second order PLL jitter transfer bounding function. See Note 3.
$PKG_{RX-PLL1}$	Rx PLL peaking with 8MHz minimum BW	Not specified		3.0	-	dB	Second order PLL jitter transfer bounding function. See Note 3.
$PKG_{RX-PLL2}$	Rx PLL peaking with 5MHz minimum BW	Not specified		1.0	-	dB	Second order PLL jitter transfer bounding function. See Note 3.
$RL_{RX-DIFF}$	Rx package plus Si differential return loss	10	-	10 for 0.05-1.25 GHz 8 for 1.25-2.5 GHz	-	dB	See Figure 4-39 of <i>PCI Express Base Specification (Rev. 2.1)</i> and Note 4.
$RL_{RX-CM}$	Common mode Rx return loss	6	-	6 (min.)	-	dB	See Figure 4-39 of <i>PCI Express Base Specification (Rev. 2.1)</i> and Note 4.
$Z_{RX-DC}$	Receiver DC common mode impedance	40	60	40	60	W	DC impedance limits are needed to guarantee Receiver detect. See Note 5.
$Z_{RX-DIFF-DC}$	DC differential impedance	80	120	Not specified		W	For 5.0 Gbps covered under $RL_{RX-DIFF}$ parameter. See Note 5.
$V_{RX-CM-AC-P}$	Rx AC common mode voltage	-	150	-	150	mVP	Measured at Rx pins into a pair of 50 $\Omega$ termination into ground. See Note 6.



Table 18: PCIe Differential Receiver Specifications (Continued)

Symbol	Parameter	2.5 Gbps		5.0 Gbps		Unit	Notes
		Min.	Max.	Min.	Max.		
$Z_{RX-HIGH-IMP-D}$ C-POS	DC input CM input impedance for $V > 0$ during reset or power down	50 k	-	50 k	-	W	Rx DC CM impedance with the Rx terminations not powered, measured over the range 0 - 200 mV with respect to ground. See Note 7.
$Z_{RX-HIGH-IMP-D}$ C-NEG	DC input CM input impedance for $V < 0$ during reset or power down	1.0 k	-	1.0 k	-	W	Rx DC CM impedance with the Rx terminations not powered, measured over the range -150 - 0 mV with respect to ground. See Note 7.
$V_{RX-IDLE-DET-DI}$ FFp-P	Electrical idle detect threshold	65	175	65	175	mV	$V_{RX-IDLE-DET-DIFFp-p} = 2 *  V_{RX-D+} - V_{RX-D-} $ . Measured at the package pins of the Receiver. See Section 4.2.4.3 of <i>PCI Express Base Specification (Rev. 2.1)</i>
$T_{RX-IDLE-DET-DI}$ FF-ENTERTIME	Unexpected electrical Idle enter detect threshold integration time	-	10	-	10	ms	An unexpected Electrical Idle ( $V_{RX-DIFFp-p} < V_{RX-IDLE-DET-DIFFp-p}$ ) must be recognized no longer then $T_{RX-IDLE-DET-DIFF-ENTERTIME}$ to signal an unexpected idle condition.
$L_{RX-SKEW}$	Lane-to-lane skew	-	20	-	8	ns	Across all Lanes on a Port, this includes variation in the length of a SKP Ordered Set at the Rx as well as any delay differences arising from the interconnect itself. See Note 8.

- Receiver eye margins are defined into a 2 x 50 W reference load. A Receiver is characterized by driving it with a signal whose characteristics are defined by the parameters specified in Table 4-10 and Table 4-11 of the *PCI Express Base Specification (Rev. 2.1)*
- The four inherent timing error parameters are defined for the convenience of Rx designers, and they are measured during Receiver tolerancing.
- Two combinations of PLL BW and peaking are specified at 5.0 Gbps to permit designers to make a trade off between the two parameters. If the PLL's minimum BW is  $\geq 8$  MHz, then up to 3.0 dB of peaking is permitted. If the PLL's minimum BW is relaxed to  $\geq 5.0$  MHz, then a tighter peaking value of 1.0 dB must be met. Note: A PLL BW extends from zero up to the value(s) defined as the minimum or maximum in the table. For 2.5 Gbps a single PLL bandwidth and peaking value of 1.5-22 MHz and 3.0 dB are defined.
- Measurements must be made for both common mode and differential return loss. In both cases the DUT must be powered up and DC isolated, and its D+/D- inputs must be in the low-Z state.
- The Rx DC Common Mode Impedance must be present when the Receiver terminations are first enabled to ensure that the Receiver Detect occurs properly. Compensation of this impedance can start immediately and the Rx Common Mode Impedance (constrained by RLRX-CM to 50 W +/-20%) must be within the specified range by the time Detect is entered.
- Common mode peak voltage is defined by the expression:  $\text{maximum}\{|(V_{d+} - V_{d-}) - V_{CMDC}|\}$ .

7. ZRX-HIGH-IMP-DC-NEG and ZRX-HIGH-IMP-DC-POS are defined respectively for negative and positive voltages at the input of the Receiver. Transmitter designers need to comprehend the large difference between >0 and <0 Rx impedances when designing Receiver detect circuits.
8. The LRX-SKEW parameter exists to handle repeaters that regenerate Refclk and introduce differing numbers of skips on different lanes.

### 3.7.2 PCIe Differential Transmitter Specifications

Table 19 lists the electrical characteristics for the PCIe differential transmitters in the Tsi721. Parameters are defined separately for 2.5 Gbps and 5.0 Gbps implementations. Table 19 is duplicated from the *PCI Express Base Specification (Rev. 2.1)* Section 4.3.3.5 Table 4-9 on page 252.

Table 19: PCIe Differential Transmitter Specifications

Symbol	Parameter	2.5 Gbps		5.0 Gbps		Unit	Notes
		Min.	Max.	Min.	Max.		
UI	Unit interval	399.88	400.12	199.94	200.06	ps	The specified UI is equivalent to a tolerance of +/- 300ppm for each Refclk source. Period does not account for SSC induced variations. See Note 1.
V <sub>TX-DIFF-PP</sub>	Differential p-p Tx voltage swing	0.8	1.2	0.8	1.2	V	As measured with compliance test load. Defined as 2* V <sub>TXD+</sub> - V <sub>TXD-</sub>  .
V <sub>TX-DIFF-PP-LOW</sub>	Low power differential p-p Tx voltage swing	0.4	1.2	0.4	1.2	V	As measured with compliance test load. Defined as 2* V <sub>TXD+</sub> - V <sub>TXD-</sub>  . See Note 9.
V <sub>TX-DE-RATIO-3.5DB</sub>	Tx de-emphasis level ratio	3.0	4.0	3.0	4.0	dB	See Section 4.3.3.9 of <i>PCI Express Base Specification (Rev. 2.1)</i> and Note 11 for information.
V <sub>TX-DE-RATIO-6DB</sub>	Tx de-emphasis level ratio	N/A	N/A	5.5	6.5	dB	See Section 4.3.3.9 of <i>PCI Express Base Specification (Rev. 2.1)</i> and Note 11 for information.
T <sub>MIN-PULSE</sub>	Instantaneous lone pulse width	Not specified		0.9	-	UI	Measured relative to rising/falling pulses. See Notes 2,10 and Figure 4-29 of <i>PCI Express Base Specification (Rev. 2.1)</i>
T <sub>TX-EYE</sub>	Transmitter eye including all jitter sources	0.75	-	0.75	-	UI	Does not include SSC or Refclk jitter. Includes Rj at 10-12. See Notes 2, 3, 4 and 10. Note that 2.5 Gbps and 5.0 Gbps use different jitter determination methods.
T <sub>TX-EYE-MEDIAN-to-MAX-JITTER</sub>	Maximum time between the jitter median and maximum deviation from the median	-	0.125	Not specified		UI	Measured differentially at zero crossing points after applying the 2.5 Gbps clock recovery function. See Note 2.

Table 19: PCIe Differential Transmitter Specifications (Continued)

Symbol	Parameter	2.5 Gbps		5.0 Gbps		Unit	Notes
		Min.	Max.	Min.	Max.		
$T_{TX-HF-DJ-DD}$	Tx deterministic jitter > 1.5 MHz	Not specified		-	0.15	UI	Deterministic jitter only. See Notes 2 and 10.
$T_{TX-LF-RMS}$	TX RMS jitter < 1.5 MHz	Not specified		3.0	-	ps RMS	Total energy measured over a 10 kHz - 1.5 MHz range
$T_{TX-RISE-FALL}$	Transmitter rise and fall time	0.125	-	0.15	-	UI	Measured differentially from 20% to 80% of swing. See Note 2 and Figure 4-28 of <i>PCI Express Base Specification (Rev. 2.1)</i>
$T_{RF-MISMATCH}$	Tx rise/fall mismatch	Not specified		-	0.1	UI	Measured from 20% to 80% differentially. See Note 2.
$BW_{TX-PLL}$	Maximum Tx PLL bandwidth	-	22	-	16	MHz	Second order PLL jitter transfer bounding function. See Note 6.
$BW_{TX-PLL-LO-3DB}$	Minimum Tx PLL BW for 3dB peaking	1.5	-	8	-	MHz	Second order PLL jitter transfer bounding function. See Notes 6 and 8.
$BW_{TX-PLL-LO-1DB}$	Minimum Tx PLL BW for 1dB peaking	Not specified		5	-	MHz	Second order PLL jitter transfer bounding function. See Notes 6 and 8.
$PKG_{TX-PLL1}$	Tx PLL peaking with 8 MHz BW	Not specified		-	3.0	dB	See Note 8.
$PKG_{TX-PLL2}$	Tx PLL peaking with 5 MHz BW	Not specified		-	1.0	dB	See Note 8.
$RL_{TX-DIFF}$	Tx package plus Si differential return loss	10	-	10 for 0.05-1.25 GHz 8 for 1.25-2.5 GHz	-	dB	For more information, refer to Figure 4-34 of <i>PCI Express Base Specification (Rev. 2.1)</i>
$RL_{TX-CM}$	Tx package plus Si common mode return loss	6	-	6	-	dB	Measured over 0.05 - 1.25 GHz range for 2.5 Gbps and 0.05 - 2.5 GHz range for 5.0 Gbps ( $S_{11}$ parameter)
$Z_{TX-DIFF-DC}$	DC differential Tx impedance	80	120	-	120	W	Low impedance defined during signaling. Parameter is captured for 5.0 GHz by $RL_{TX-DIFF}$ .
$V_{TX-CM-AC-PP}$	Tx AC common mode voltage (5.0 Gbps)	Not specified		-	100	mV	See Note 5.
$V_{TX-CM-AC-P}$	TX AC common mode voltage (2.5 Gbps)	20	-	Not specified		mV	See Note 5.

Table 19: PCIe Differential Transmitter Specifications (Continued)

Symbol	Parameter	2.5 Gbps		5.0 Gbps		Unit	Notes
		Min.	Max.	Min.	Max.		
$I_{TX-SHORT}$	Transmitter short-circuit current limit	-	90	-	90	mA	The total current transmitter can supply when shorted to ground.
$V_{TX-DC-CM}$	Transmitter DC common-mode voltage	0	3.6	0	3.6	V	The allowed DC common-mode voltage at the Transmitter pins under any condition.
$V_{TX-CM-DC-ATIV}$ $E-IDLE-DELTA$	Absolute delta of DC common-mode voltage during L0 and Electrical Idle	0	100	0	100	mV	$ V_{TX-CM-DC[during L0]} - V_{TX-CM-Idle-DC[during Electrical Idle]}  \leq 100mV$ $V_{TX-CM-DC} = DC_{(avg)} \text{ of }  V_{TX-D+} + V_{TX-D-} /2$ $V_{TX-CM-Idle-DC} = DC_{(avg)} \text{ of }  V_{TX-D+} + V_{TX-D-} /2 \text{ [Electrical Idle]}$
$V_{TX-CM-DC-LINE-DELTA}$	Absolute delta of DC common-mode voltage between D+ and D-	0	25	0	25	mV	$ V_{TX-CM-DC-D+[during L0]} - V_{TX-CM-DC-D-[during L0]}  \leq 25mV$ $V_{TX-CM-DC-D+} = DC_{(avg)} \text{ of }  V_{TX-D+}  \text{ [during L0]}$ $V_{TX-CM-DC-D-} = DC_{(avg)} \text{ of }  V_{TX-D-}  \text{ [during L0]}$
$V_{TX-IDLE-DIFF\_A}$ C-p	Electrical idle differential peak output voltage	0	20	0	20	mV	$V_{TX-IDLE-DIFFp} =  V_{TX-Idle-D+} - V_{TX-Idle-D-}  \leq 20mV$ . Voltage must be high pass filtered to remove any DC component.
$V_{TX-IDLE-DIFF\_DC}$	DC electrical idle differential output voltage	Not specified		0	5	mV	$V_{TX-IDLE-DIFF-DC} =  V_{TX-Idle-D+} - V_{TX-Idle-D-}  \leq 5 \text{ mV}$ . Voltage must be low pass filtered to remove any AC component. Filter characteristics complementary to those for $V_{TX-IDLE-DIFF-AC-p}$
$V_{TX-RCV-DETECT}$	The amount of voltage change allowed during receiver detection	-	600	-	600	mV	The total amount of voltage change in a positive direction that a Transmitter can apply to sense whether a low impedance Receiver is present. Note: Receivers display substantially different impedance for $V_{IN} < 0$ versus $V_{IN} > 0$ . See Table 4-12 of <i>PCI Express Base Specification (Rev. 2.1)</i> for more information.
$T_{TX-IDLE-MIN}$	Minimum time spent in electrical idle	20	-	20	-	ns	Minimum time a Transmitter must be in Electrical Idle

Table 19: PCIe Differential Transmitter Specifications (Continued)

Symbol	Parameter	2.5 Gbps		5.0 Gbps		Unit	Notes
		Min.	Max.	Min.	Max.		
$T_{TX-IDLE-SET-TO-IDLE}$	Maximum time to transition to a valid electrical idle after sending an EIOS	-	8	-	8	ns	After sending the required numbers of EIOSs, the Transmitter must meet all Electrical Idle specifications within this time. This is measured from the end of the last UI of the last EIOS to the Transmitter in Electrical Idle.
$T_{TX-IDLE-SET-TO-DIFF-DATA}$	Maximum time to transition to valid differential signaling after leaving electrical idle	-	8	-	8	ns	Maximum time to transition to valid differential signaling after leaving Electrical Idle. This is considered a de-bounce time to the Tx.
$T_{CROSSLINK}$	Crosslink random timeout	-	1	-	1	ms	This random timeout helps resolve conflicts in the crosslink configuration.
$L_{TX-SKEW}$	Lane-to-lane output skew	-	500 ps + 2 UI	-	500 ps + 2 UI	ps	Between any two Lanes within a single Transmitter.
$C_{TX}$	AC coupling capacitor	75	200	75	200	nF	All Transmitters must be AC coupled. The AC coupling is required either within the media or within the transmitting component itself.

1. SSC permits a +0, -5000 ppm modulation on the clock frequency at a modulation rate not to exceed 33 kHz.
2. Measurements at 5.0 Gbps require an oscilloscope with a bandwidth of  $\geq 12.5$  GHz, or equivalent, while measurements made at 2.5 Gbps require a scope with at least 6.2 GHz of bandwidth. Measurements at 5.0 Gbps must deconvolve effects of compliance test board to produce an effective measurement at Tx pins. 2.5 Gbps may be measured within 200 mils of Tx device's pins, although deconvolution is recommended. For measurement setup information, refer to Figure 4-23 and Figure 4-24 of *PCI Express Base Specification (Rev. 2.1)*. At least 106 UI of data must be acquired.
3. Transmitter jitter is measured by driving the Transmitter under test with a low jitter "ideal" clock and connecting the DUT to a reference load.
4. Transmitter raw jitter data must be convolved with a filtering function that represents the worst case CDR tracking BW. 2.5 Gbps use different filter functions that are defined in Figure 4-21 of *PCI Express Base Specification (Rev. 2.1)*. After the convolution process has been applied, the center of the resulting eye must be determined and used as a reference point for obtaining eye voltage and margins.
5. VTX-AC-CM-PP and VTX-AC-CM-P are defined in Section 4.3.3.7 of *PCI Express Base Specification (Rev. 2.1)*. Measurement is made over at least 106 UI.
6. The Tx PLL Bandwidth must lie between the minimum and maximum ranges displayed in the table. PLL peaking must lie below the value listed. Note: the PLL B/W extends from zero up to the value(s) specified in the table.
7. Measurements are made for both common mode and differential return loss. The DUT must be powered up and DC isolated, and its data+/data- outputs must be in the low-Z state at a static value.

8. A single combination of PLL BW and peaking is specified for 2.5 Gbps implementations. For 5.0 Gbps, two combinations of PLL BW and peaking are specified to permit designers to make a trade-off between the two parameters. If the PLL's minimum BW is  $\geq 8$  MHz, the up to 3.0 dB of peaking is permitted. If the PLL's minimum BW is related to  $\geq 5.0$  MHz, then a tighter peaking value of 1.0 dB must be met. In both cases, the maximum PLL BW is 16 MHz.
9. Low swing output, defined by VTX-DIFF-PP-LOW must be implemented as displayed in Figure 4-27 of the *PCI Express Base Specification (Rev. 2.1)* with no de-emphasis.
10. For 5.0 Gbps, de-emphasis timing jitter must be removed. An additional HPF function must be applied as displayed in Figure 4-21 of *PCI Express Base Specification (Rev. 2.1)*. This parameter is measured by accumulating a record of 106 UI while the DUT outputs a compliance pattern. TMIN-PULSE is defined to be nominally 1 UI wide and is bordered on both sides by pulses of the opposite polarity. Refer to Figure 4-29 of *PCI Express Base Specification (Rev. 2.1)*.
11. Root complex Tx de-emphasis is configured from Upstream controller. Downstream Tx de-emphasis is set through a command, issues at 2.5 Gbps. For information, refer to the appropriate location in Section 4.2 of *PCI Express Base Specification (Rev. 2.1)*.

### 3.7.3 RapidIO SerDes Characteristics

#### 3.7.3.1 Overview

The Tsi721's SerDes are in full compliance to the RapidIO AC specifications for the LP-Serial physical layer [5]. This section provides those specifications for reference only; the user should see the specification for complete requirements.

Chapter 9 of the specification, "1.25 Gbaud, 2.5 Gbaud, and 3.125 Gbaud LP-Serial Links" defines Level I links compatible with the 1.3 version of the Physical Layer Specification, that supports throughput rates of 1.25, 2.5, and 3.125 Gbps.

Chapter 10 of the specification, "5 Gbaud and 6.25 Gbaud LP-Serial Links" defines Level II links that support throughput rates of 5 and 6.25 Gbps.

A Level I link should:

- Allow 1.25, 2.5, or 3.125 Gbps rates
- Support AC coupling
- Support hot plug
- Support short run (SR) and long run (LR) links achieved with two transmitters
- Support single receiver specification that will accept signals from both the short run and long run transmitter specifications
- Achieve Bit Error Ratio of lower than  $10^{-12}$  per lane

A Level II link should:

- Allow 5 Gbps baud rates
- Support AC coupling and optional DC coupling
- Support hot plug
- Support short run (SR), and medium run (MR) links achieved with two transmitters and two receivers
- Achieve Bit Error Ratio of lower than  $10^{-15}$  per lane but test requirements will be verified to  $10^{-12}$  per lane

Together, these specifications allow for solutions ranging from simple chip-to-chip interconnect to board-to-board interconnect driving two connectors across a backplane. The faster and wider electrical interfaces specified here are required to provide higher density and/or lower cost interfaces.

The short run defines a transmitter and a receiver that should be used mainly for chip-to-chip connections on either the same printed circuit board or across a single connector. This covers the case where connections are made to a mezzanine (daughter) card. The smaller swings of the short run specification reduces the overall power used by the transceivers.

The Level I long run defines a transmitter and receiver that use larger voltage swings and channel equalization that allows a user to drive signals across two connectors and backplanes.

The two transmitter specifications allows for a medium run specification that also uses larger voltage swings that can drive signals across a backplane but simplifies the receiver requirements to minimize power and complexity. This option has been included to allow the system integrator to deploy links that take advantage of either channel materials and/or construction techniques that reduce channel loss to achieve lower power systems.

All unit intervals are specified with a tolerance of  $\pm 100$  ppm. The worst case frequency difference between any transmit and receive clock is 200 ppm.

The electrical specifications are based on loss, jitter, and channel cross-talk budgets and defines the characteristics required to communicate between a transmitter and a receiver using nominally 100 Ohm differential copper signal traces on a printed circuit board. Rather than specifying materials, channel components, or configurations, this specification focuses on effective channel characteristics. Therefore, a short length of poorer material should be equivalent to a longer length of premium material. A 'length' is effectively defined in terms of its attenuation rather than physical distance.

### 3.7.3.2 Definition of Amplitude and Swing

LP-Serial links use differential signaling. This section defines the terms used in the description and specification of these differential signals. Figure 6 shows how these signals are defined and sets out the relationship between absolute and differential voltage amplitude. The figure shows waveforms for either the transmitter output (TD and TD\_N) or a receiver input (RD and RD\_N).

Figure 6: S-RIO Definition of Transmitter Amplitude and Swing

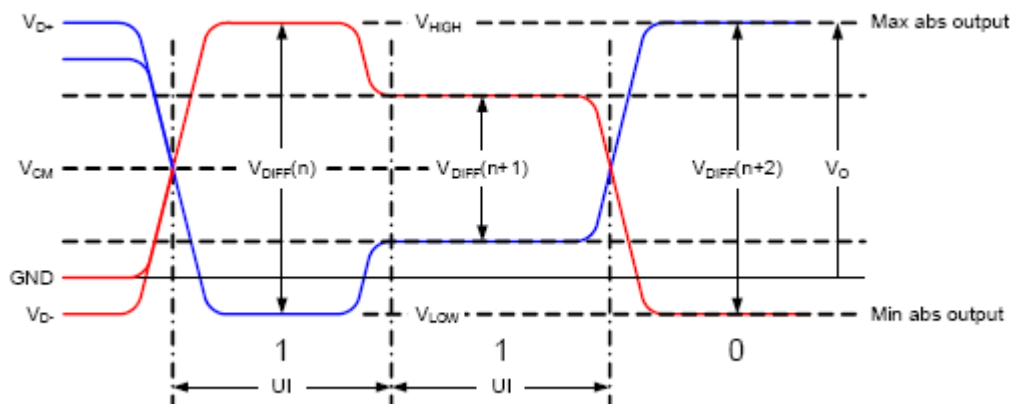

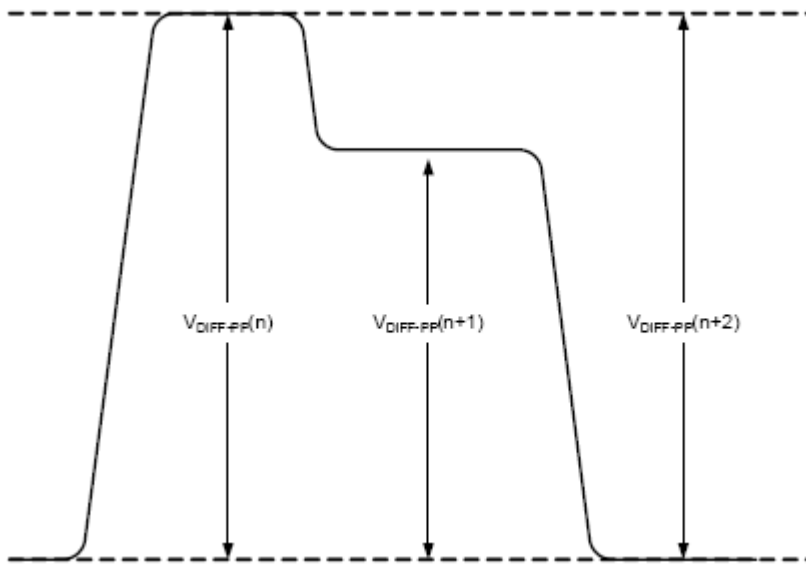

Each signal swings between the voltages VHIGH and VLOW where:

$$V_{HIGH} > V_{LOW}$$

The differential voltage, VDIFF is defined as:

$$V_{DIFF} = V_{D+} - V_{D-}$$

where VD+ is the voltage on the positive conductor and VD- is the voltage on the negative conductor of a differential transmission line. VDIFF represents either the differential output signal of the transmitter, VOD, or the differential input signal of the receiver, VID where:

$$V_{OD} = V_{TD} - V_{TD}$$

and

$$V_{ID} = V_{RD} - V_{RD}$$

The common mode voltage, VCM, is defined as the average or mean voltage present on the same differential pair. Therefore:

$$V_{CM} = |V_{D+} + V_{D-}| / 2$$

The maximum value, or the peak-to-peak differential voltage, is calculated on a per unit interval and is defined as:

$$V_{DIFFp-p} = 2 \times \max |V_{D+} - V_{D-}|$$

because the differential signal ranges from VD+ - VD- to -(VD+ - VD-)

To illustrate these definitions using real values, consider the case of a CML (Current Mode Logic) transmitter and each of its outputs, TD and TD\_N, has a swing that goes between VHIGH = 2.5V and VLOW = 2.0V, inclusive. Using these values the common mode voltage is calculated to be 2.25 V and the single-ended peak voltage swing of the signals TD and TD\_N is 500 mVpp. The differential output signal ranges between 500 mV and -500 mV, inclusive. therefore the peak-to-peak differential voltage is 1000 mVppd.



### 3.7.3.3 1.25 Gbps, 2.5 Gbps, and 3.125 Gbps LP-Serial Links

This section explains the requirements for Level I RapidIO LP-Serial short and long run electrical interfaces of nominal baud rates of 1.25, 2.5, and 3.125 Gbps using NRZ coding (thus, 1 bit per symbol at the electrical level). The Tsi721's SerDes meet all of the requirements listed below. The electrical interface is based on a high speed, low voltage logic with a nominal differential impedance of 100 Ohm. Connections are point-to-point balanced differential pair and signaling is unidirectional.

The level of links defined in this section are identical to those defined in the *RapidIO Interconnect Specification (Revision 2.1)*, 1x/4x LP-Serial Electrical Specification.

### 3.7.3.4 Equalization

With the use of high speed serial links, the interconnect media will cause degradation of the signal at the receiver. Effects such as Inter-Symbol Interference (ISI) or data dependent jitter are produced. This loss can be large enough to degrade the eye opening at the receiver beyond what is allowed in the specification. To negate a portion of these effects, equalization can be used in the transmitter and/or receiver, but it is not required at baud rates less than 3.125 Gbps.

### 3.7.3.5 Explanatory Note on Level I Transmitter and Receiver Specifications

AC electrical specifications are provided for the transmitter and receiver. Long run and short run interfaces at three baud rates are described.

The parameters for the AC electrical specifications are guided by the XAUI electrical interface specified in Clause 47 of IEEE 802.3ae-2002.[1] The goal of this standard is that electrical designs for Level I electrical designs can reuse XAUI, suitably modified for applications at the baud intervals and runs described herein.

### 3.7.3.6 Level I Electrical Specification

#### 3.7.3.6.1 Level I Transmitter Characteristics

Level I LP-Serial transmitter electrical and timing specifications are stated in the text and tables of this section. The differential return loss,  $S_{11}$ , of the transmitter in each case must be better than:

- -10 dB for (Baud Frequency) / 10 < Freq(f) < 625 MHz, and
- -10 dB + 10log(f/625 MHz) dB for 625 MHz <= Freq(f) <= Baud Frequency

The reference impedance for the differential return loss measurements is 100 Ohm resistive. Differential return loss includes contributions from on-chip circuitry, chip packaging and any off-chip components related to the driver. The output impedance requirement applies to all valid output levels.

The Tsi721 satisfies the specification requirement that the 20%-80% rise/fall time of the transmitter, as measured at the transmitter output, in each case has a minimum value 60 ps.

Similarly, the timing skew at the output of an LP-Serial transmitter between the two signals that comprise a differential pair does not exceed 25 ps at 1.25 Gbps, 20 ps at 2.5 Gbps, and 15 ps at 3.125 Gbps.

### 3.7.3.6.2 Level I Short Run Transmitter Specifications

Table 20: Level I Short Run Transmitter AC Timing Specifications

Symbol	Characteristic	Reference	Minimum	Typical	Maximum	Units
T_Baud	Baud rate	Section 9.4.1.2	1.25	-	3.125	Gbps
V <sub>O</sub>	Absolute output voltage	Section 9.4.1.3	-0.40	-	2.30	Volts
T_Vdiff	Output differential voltage (into floating load Rload = 100 Ohm)	Section 9.4.1.3	500	-	1000	mVppd
T_Rd	Differential resistance	Section 9.4.1.5	80	100	120	Ohm
T_tr, T_tf	Recommended output rise and fall times (20% to 80%)	Section 9.4.1.4	60	-	-	ps
T_SDD22	Differential output return loss (T_baud/10 ≤ f < T_baud/2)	Section 9.4.1.6	-	-	-	dB
	Differential output return loss (T_baud/10 ≤ f < T_baud/2)		-	-	-	dB
T_TCC22	Common mode return loss (625 MHz ≤ f ≤ T_baud)	Section 9.4.1.6	-	-	Note 3	dB
T_Ncm	Transmitter common mode noise <sup>1</sup>		-	-	Note 4	mVppd
T_Vcm	Output common mode voltage	Load Type 0 <sup>2</sup>	0	-	2.1	V
S <sub>MO</sub>	Multiple output skew, N ≤ 4	Section 9.4.1.7	-	-	1000	ps
S <sub>MO</sub>	Multiple output skew, N > 4	Section 9.4.1.7	-	-	2UI + 1000	ps
UI	Unit interval	-	80	-	800	ps

1. For all Load Types: R\_Rdin = 100 Ohm +/- 20 Ohm.
2. Load Type 0 with min. T\_Vdiff, AC-coupling or floating load.
3. It is suggested that T\_SCC22 be -6 dB to be compatible with Level II transmitter requirements.
4. It is suggested that T\_Ncm be limited to 5% of T\_Vdiff to be compatible with Level II transmitter requirements.

### 3.7.4 Level I Long Run Transmitter Specifications

**Table 21: Level I Long Run Transmitter AC Timing Specifications**

Characteristics	Symbol	Reference	Min	Typ	Max	Units
Baud Rate	T_Baud	Section 9.4.2.2	1.25	-	3.125	Gbps
Absolute Output Voltage	V <sub>O</sub>	Section 9.4.2.3	-0.40	-	2.30	Volts
Output Differential Voltage (into floating load Rload = 100 Ohm)	T_Vdiff	Section 9.4.2.3	800	-	1600	mVppd
Differential Resistance	T_Rd	Section 9.4.1.5	80	100	120	Ohm
Recommended output rise and fall times (20% to 80%)	T_tr, T_tf	-	60	-	-	ps
Differential Output Return Loss (T_baud/10 ≤ f < T_baud/2)	T_SDD22	Section 9.4.1.6	-	-	-	dB
Differential Output Return Loss (T_baud/10 ≤ f < T_baud/2)			-	-	-	dB
Common Mode Return Loss (625 MHz ≤ f ≤ T_baud)	T_TCC22	Section 9.4.1.6	-	-	Note 3	dB
Transmitter Common Mode Noise <sup>1</sup>	T_Ncm		-	-	Note 4	mVppd
Output Common Mode Voltage	T_Vcm	Load Type 0 <sup>2</sup>	0	-	2.1	V
Multiple output skew, N ≤ 4	S <sub>MO</sub>	-	-	-	1000	ps
Multiple output skew, N > 4	S <sub>MO</sub>	-	-	-	2UI + 1000	ps
Unit Interval	UI	-	80	-	800	ps

1. For all Load Types: R\_Rdin = 100 Ohm +/- 20 Ohm.
2. Load Type 0 with min. T\_Vdiff, AC-coupling or floating load.
3. It is suggested that T\_SCC22 be -6 dB to be compatible with Level II transmitter requirements.
4. It is suggested that T\_Ncm be limited to 5% of T\_Vdiff to be compatible with Level II transmitter requirements.

For each baud rate at which the LP-Serial transmitter is specified to operate, the output eye pattern of the transmitter falls entirely within the unshaded portion of the Transmitter Output Compliance Mask displayed in [Figure 7](#) when measured at the output pins of the device and the device is driving a 100 Ohm + 5% differential resistive load. The specification allows the output eye pattern of a LP-Serial transmitter that implements pre-emphasis (to equalize the link and reduce inter-symbol interference) to only comply with the Transmitter Output Compliance Mask when pre-emphasis is disabled or minimized.

Figure 7: S-RIO Transition Symbol Transmit Eye Mask

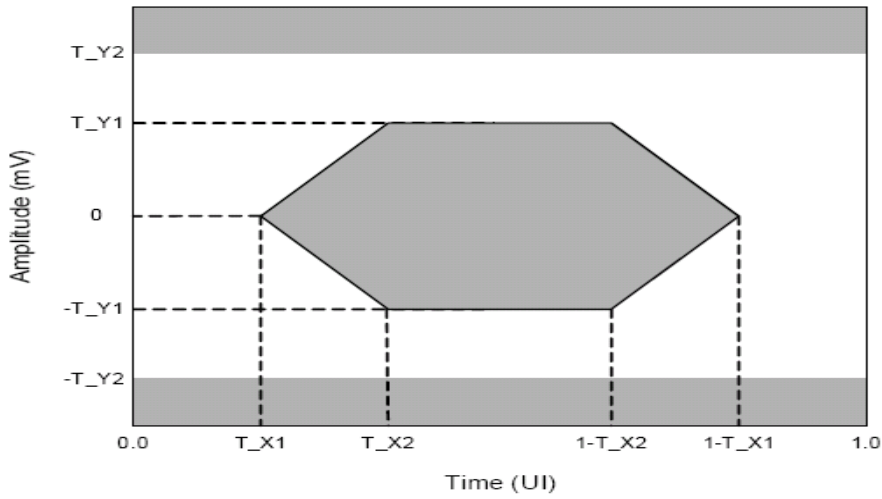

Table 22: Level I Near-End (Tx) Template Intervals

Characteristic	Symbol	Near-End SR Value	Near-End LR Value	Units
Eye mask	T_X1	0.17	0.17	UI
Eye mask	T_X2	0.39	0.39	UI
Eye mask	T_Y1	250	400	mV
Eye mask	T_Y2	500	800	mV
Eye mask	T_Y3	N/A	N/A	mV
Uncorrelated bounded high probability jitter	T_UBHPJ	0.17	0.17	U <sub>lpp</sub>
Duty cycle distortion	T_DCD	0.05	0.05	U <sub>lpp</sub>
Total jitter	T_TJ	0.35	0.35	U <sub>lpp</sub>

### 3.7.4.0.1 Level I Receiver Specifications

Level I LP-Serial receiver electrical and timing specifications are stated in the text and tables of this section.

Table 23: Level I Receiver Electrical Input Specifications

Characteristic	Symbol	Reference	Minimum	Typical	Maximum	Units
Rx baud rate (1.25 Gbps)	R_Baud	-	-	1.250	-	Gbps
Rx baud rate (2.5 Gbps)		-	-	2.500	-	Gbps
Rx baud rate (3.125 Gbps)		-	-	3.125	-	Gbps
Absolute input voltage	R_Vin	Section 9.4.3.4	-	-	-	-
Input differential voltage	R_Vdiff	Section 9.4.3.3	200	-	1600	mVppd
Differential resistance	R_Rdin	Section 9.4.3.7	80	100	120	Ohm
Differential input return loss (100 MHz $\leq$ f $\leq$ R_Baud/2)	R_SDD11	Section 9.4.3.7	-	-	-	dB
Differential input return loss (R_Baud/2 $\leq$ f $\leq$ R_Baud)			-	-	-	-
Common mode input return loss (625 MHz $\leq$ f $\leq$ T_baud)	R_SCC11	Section 9.4.3.7	-	-	-	dB
Termination voltage <sup>1,2</sup>	R_Vtt	R_Vtt floating <sup>4</sup>	Not specified			V
Input common mode voltage <sup>1,2</sup>	R_Vrcm	R_Vtt floating <sup>3,4</sup>	-0.05	-	1.85	V
Wander divider	n	-	-	10	-	-

1. Input common mode voltage for AC-coupled or floating load input with min. T\_Vdiff.
2. Receiver is required to implement at least one of the specified nominal R\_Vtt values, and usually implements only one of these values. Receiver is only required to meet R\_Vrcm parameter values that correspond to R\_Vtt values supported.
3. Input common mode voltage for AC-coupled or floating load input with min. T\_Vdiff.
4. For floating load, input resistance must be > 1K Ohm.

Table 24: Level I Receiver Input Jitter Tolerance Specifications

Characteristic	Symbol	Reference	Minimum	Typical	Maximum	Units
Bit error ratio	BER	-	-	-	$10^{-12}$	-
Bounded high probability jitter	R_BHPJ	Section 9.4.3.8	-	-	0.37	U <sub>pp</sub>
Sinusoidal jitter, maximum	R_SJ-max	Section 9.4.3.8	-	-	8.5	U <sub>pp</sub>
Sinusoidal jitter, high frequency	R_SJ-hf	Section 9.4.3.8	-	-	0.1	U <sub>pp</sub>
Total Jitter (Does not include sinusoidal jitter)	R_TJ	Section 9.4.3.8	-	-	0.55	U <sub>pp</sub>
Total jitter tolerance <sup>1</sup>	R_JT	-	-	-	0.65	U <sub>pp</sub>
Eye mask	R_X1	Section 9.4.3.8	-	-	0.275	UI
Eye mask	R_Y1	Section 9.4.3.8	-	-	100	mV
Eye mask	R_Y2	Section 9.4.3.8	-	-	800	mV

1. Total jitter is composed of three components, deterministic jitter, random jitter and single frequency sinusoidal jitter. The sinusoidal jitter can have any amplitude and frequency in the unshaded region of the following figure. The sinusoidal jitter component is included to ensure margin for the low frequency jitter, wander, noise, crosstalk and other variable system effects.

Figure 8: S-RIO Single Frequency Sinusoidal Jitter Limits

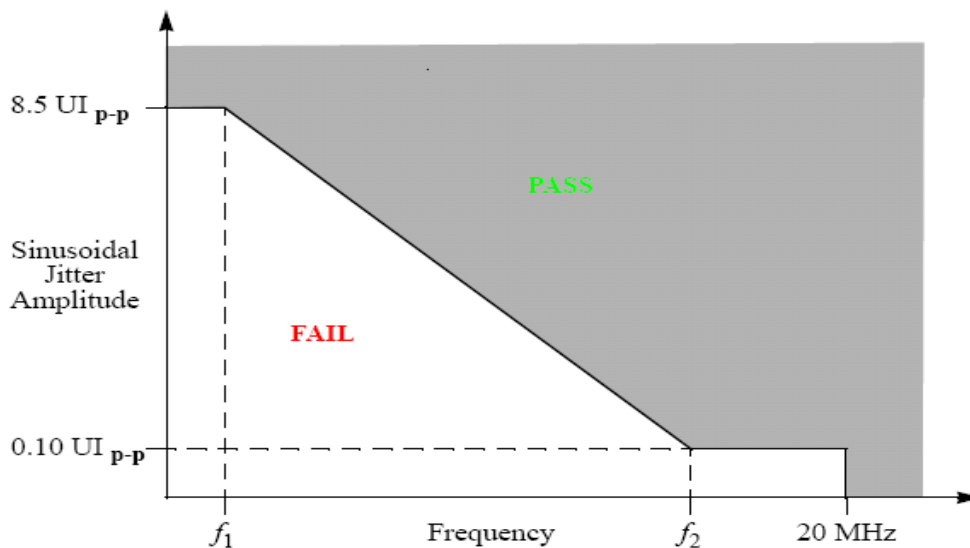

### 3.7.4.0.2 Level I Receiver Eye Diagram

For each baud rate at which the a LP-Serial receiver is specified to operate, the receiver meets the corresponding Bit Error Ratio specification in Table 25 when the eye pattern of the receiver test signal (exclusive of sinusoidal jitter) falls entirely within the unshaded portion of the Receiver Input Compliance Mask displayed in Figure 9. The eye pattern of the receiver test signal is measured at the input pins of the receiving device with the device replaced with a 100 Ohm + 5% differential resistive load.

Figure 9: S-RIO Level I Receiver Input Mask

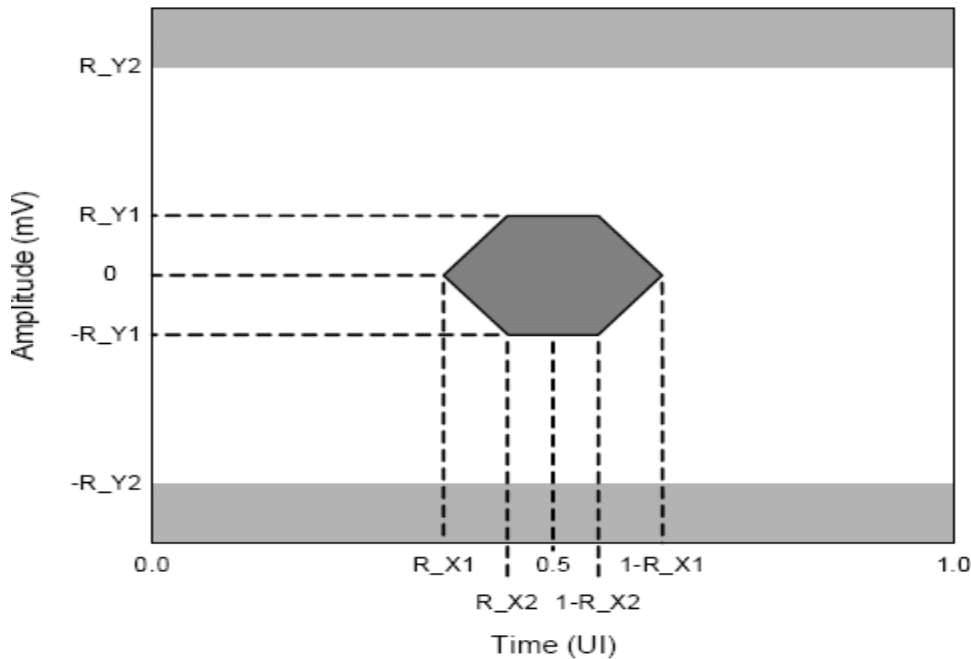

Table 25: Level I Far-End (Rx) Template Intervals

Characteristic	Symbol	Far-End Value	Units
Eye mask	R_X1	0.275	UI
Eye mask	R_Y1	100	mV
Eye mask	R_Y2	800	mV
High probability jitter	R_HPJ	0.37	U <sub>lpp</sub>
Total Jitter (Does not include sinusoidal jitter)	R_TJ	0.55	U <sub>lpp</sub>

### 3.7.4.1 5 Gbps LP-Serial Links

This chapter describes the requirements for Level II RapidIO LP-Serial short and medium electrical interfaces of nominal baud rates of 5.0. Gbps using NRZ coding (thus, 1 bit per symbol at the electrical level). A compliant device must meet all of the requirements listed below. The electrical interface is based on a high speed low voltage logic with a nominal differential impedance of 100 Ohm. Connections are point-to-point balanced differential pair and signaling is unidirectional.

### 3.7.4.2 Explanatory Note on Level II Transmitter and Receiver Specifications

AC electrical specifications are provided for transmitters and receivers. The parameters for the AC electrical specifications are guided by the OIF CEI Electrical and Jitter Inter-operability agreement for CEI-6G-SR and CEI-6G-LR.

OIF CEI-6G-SR and CEI-6G-LR have similar application goals to S-RIO, as described in Section 10.1, "Level II Application Goals." The goal of this standard is that electrical designs for S-RIO can reuse electrical designs for OIF CEI-6G, suitably modified for applications at the baud intervals and runs described herein.

### 3.7.4.3 Level II Electrical Specifications

The electrical interface is based on high speed, low voltage logic with nominal differential impedance of 100 Ohm. Connections are point-to-point balanced differential pair and signaling is unidirectional.

#### 3.7.4.3.1 Level II Transmitter Characteristics

Level II LP-Serial transmitter electrical and timing specifications are stated in the text and tables of this section.

The differential return loss must be better than A0 from f0 to f1 and better than

$$A0 + \text{Slope} \cdot \log_{10}(f/f_1)$$

Where f is the frequency from f1 to f2 (see section 8.5.11, Figure 8-12 of the *RapidIO Specification (Rev. 2.1)*). Differential return loss is measured at compliance points T and R. If AC coupling is used, then all components (internal or external) are to be included in this requirement. The reference impedance for the differential return loss measurements is 100 Ohm.

Common mode return loss measurement must be better than -6dB between a minimum frequency of 100 MHz and a maximum frequency of 0.75 times the baud rate. The reference impedance for the common mode return loss is 25 Ohm.

The Tsi721 satisfies the specification requirement that the 20%-80% rise/fall time of the transmitter, as measured at the transmitter output, in each case has a minimum value 30 ps.

Similarly, the timing skew at the output of an LP-Serial transmitter between the two signals that comprise a differential pair does not exceed 10 ps at 5.0.



### 3.7.4.3.2 Level II Short Run Transmitter Specifications

Table 26: Level II Short Run Transmitter Output Electrical Specifications

Characteristic	Symbol	Reference	Minimum	Typical	Maximum	Units
Baud rate (5 Gbps)	T_Baud	Section 10.3.2.1.2	5.00 -0.01%	5.00	5.00 +0.01%	Gbps
Absolute output voltage	V <sub>O</sub>	Section 10.3.2.1.3	-0.40	-	2.30	Volts
Output differential voltage (into floating load R <sub>load</sub> = 100 Ohm)	T_Vdiff	Section 10.3.2.1.3	400	-	750	mVppd
Differential resistance	T_Rd	Section 10.3.2.1.6	80	100	120	Ohm
Recommended output rise and fall times (20% to 80%)	T <sub>tr</sub> , T <sub>tf</sub>	Section 10.3.2.1.4	30	-	-	ps
Differential output return loss (100 MHz to 0.5 *T_Baud)	T_SDD22	Section 10.3.2.1.6	-	-	-8	dB
Differential output return loss (0.5*T_Baud to T_Baud)			-	-	-	dB
Common mode return loss (100 MHz to 0.75 *T_Baud)	T_TCC22	Section 10.3.2.1.6	-	-	-6	dB
Transmitter common mode noise	T_Ncm	-	-	-	5% of T_Vdiff	mVppd
Output common mode voltage	T_Vcm	Load Type 0 <sup>1,2,3,4</sup> Section 8.5.3	0.0	-	1.8	V
		Load Type 1 <sup>1,3,4,6</sup> Section 8.5.3	735	-	1135	mV
		Load Type 2 <sup>1,3,4</sup> Section 8.5.3	550	-	1060	mV
		Load Type 3 <sup>1,3,4,5</sup> Section 8.5.3	490	-	850	mV

1. For all Load Types: R<sub>Rdin</sub> = 100 Ohm + 20 Ohm. For V<sub>cm</sub> definition, see [Figure 6](#).

2. Load Type 0 with min T\_Vdiff, AC-Coupling or floating load.
  3. For load Type 1 through 3:  $R_{Zvt} < 30 \text{ Ohm}$ ; Vtt is defined for each load type as follows: Load Type 1  $R_{Vtt} = 1.2V +5\% / -8\%$ ; Load Type 2  $R_{Vtt} = 1.0V +5\% / -8\%$ ; Load Type 3  $R_{Vtt} = 0.8V +5\% / -8\%$ .
  4. DC Coupling compliance is optional (Type 1 through 3). Only Transmitters that support DC coupling are required to meet this parameter. It is acceptable for a transmitter to restrict the range of T\_Vdiff in order to comply with the specified T\_Vcm range. For a transmitter which supports multiple T\_Vdiff levels, it is acceptable for a transmitter to claim DC Coupling Compliance if it meets the T\_Vcm ranges for at least one of its T\_Vdiff setting as long as those setting(s) that are compliant are indicated.
  5. Simple CML transmitters designed using  $VDD > 1.2V$  can still claim DC compliance if this parameter is not met.
  6. Simple CML transmitters designed using  $VDD < 0.8V$  can still claim DC compliance if this parameter is not met.
1. The transmitter must be able to produce a minimum T\_Vdiff greater than or equal to 800mVppd. In applications where the channel is better than the worst case allowed, a Transmitter device can be provisioned to produce T\_Vdiff less than this minimum value, but greater than or equal to 400mVppd, and is still compliant with this specification.
  2. Load Type 0 with min T\_Vdiff, AC-Coupling or floating load.
  3. For load Type 1:  $R_{Zvt} < 30 \text{ Ohm}$ ; T\_Vtt and  $R_{Vtt} = 1.2V +5\% / -8\%$ .
  4. DC coupling compliance is optional (Load Type 1). Only Transmitters that support DC coupling are required to meet this parameter.

### 3.7.4.3.3 Level II Medium Transmitter Specifications

Table 27: Level II Medium Run Transmitter Output Electrical Specifications

Characteristic	Symbol	Reference	Minimum	Typical	Maximum	Units
Baud rate (5 Gbps)	T_Baud	Section 10.4.2.1.2	5.00 -0.01%	5.00	5.00 +0.01%	Gbps
Absolute output voltage	V <sub>O</sub>	Section 10.4.2.1.3	-0.40	-	2.30	Volts
Output differential voltage (into floating load Rload = 100 Ohm)	T_Vdiff	Section 10.4.2.1.3 <sup>1</sup>	800	-	1200	mVppd
Differential resistance	T_Rd	Section 10.4.2.1.6	80	100	120	Ohm
Recommended output rise and fall times (20% to 80%)	T_tr, T_tf	Section 10.4.2.1.4	30	-	-	ps
Differential output return loss (100 MHz to 0.5 *T_Baud)	T_SDD22	Section 10.4.2.1.6	-	-	-8	dB
Differential output return loss (0.5*T_Baud to T_Baud)			-	-	-	dB
Common mode return loss (100 MHz to 0.75 *T_Baud)	T_TCC22	Section 10.4.2.1.6	-	-	-6	dB
Transmitter common mode noise	T_Ncm	-	-	-	5% of T_Vdiff	mVppd

Table 27: Level II Medium Run Transmitter Output Electrical Specifications (Continued)

Characteristic	Symbol	Reference	Minimum	Typical	Maximum	Units
Output common mode voltage	T_Vcm	Load Type 0 <sup>2</sup> Section 8.5.3	100	-	1700	mV
		Load Type 1 <sup>3,4</sup> Section 8.5.3	630	-	1100	mV

1. The transmitter must be able to produce a minimum T\_Vdiff greater than or equal to 800mVppd. In applications where the channel is better than the worst case allowed, a Transmitter device can be provisioned to produce T\_Vdiff less than this minimum value, but greater than or equal to 400mVppd, and is still compliant with this specification.
2. Load Type 0 with min T\_Vdiff, AC-Coupling or floating load.
3. For load Type 1: R\_Zvt < 30 Ohm; T\_Vtt and R\_Vtt = 1.2V +5% / - 8%.
4. DC coupling compliance is optional (Load Type 1). Only Transmitters that support DC coupling are required to meet this parameter.

For 5 Gbps links, the Transmitters eye mask will also be evaluated during the steady-state where there are no symbol transitions – for example, a 1 followed by a 1 or a 0 followed by a 0 – and the signal has been de-emphasized. This additional transmitter eye mask constraint is displayed in the following figure.

Figure 10: Transition and Steady State Symbol Eye Mask

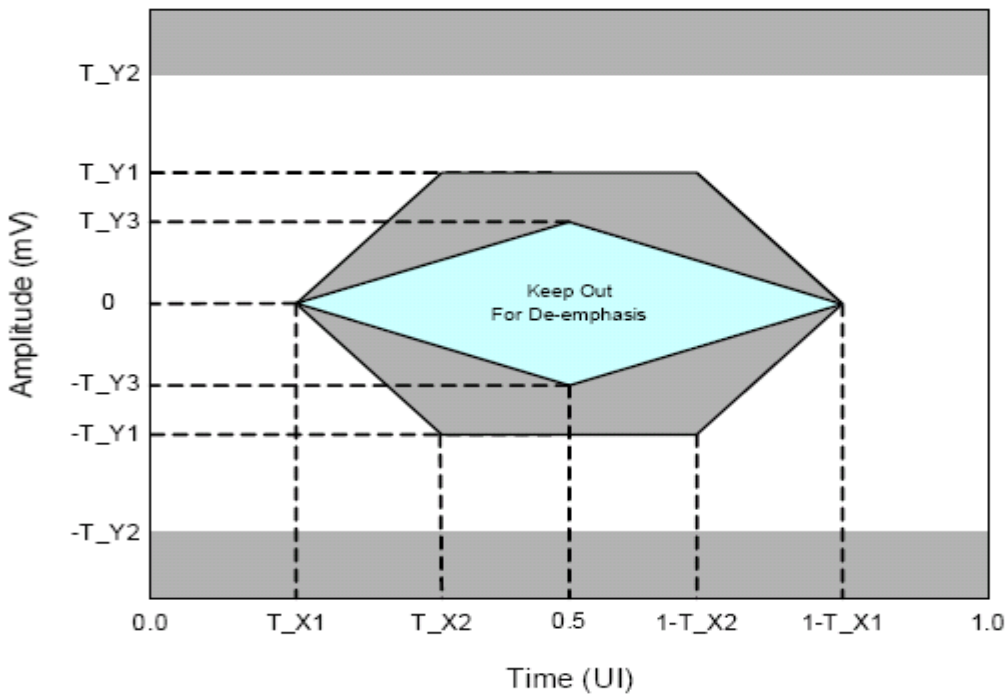

During the steady-state, the eye mask prevents the transmitter from de-emphasizing the low frequency content of the data too much and limiting the available signal-to-noise at the receiver. The de-emphasis introduces a jitter artifact that is not accounted for in this eye mask. This additional jitter is caused by the finite rise/fall time of the transmitter and the non-uniform voltage swing between the transitions. This additional deterministic jitter must be accounted for as part of the high probability jitter and is specified in the following table.

**Table 28: Level II Medium Run Near-End (Tx) Template Intervals**

Characteristic	Symbol	Near-End MRValue	Comments	Units
Eye mask	T_X1	0.15	-	UI
Eye mask	T_X2	0.40	-	UI
Eye mask	T_Y1	200	For connection to short run Rx	mV
		400	For connection to long run Rx	
Eye mask	T_Y2	375	For connection to short run Rx	mV
		600	For connection to long run Rx	
Eye mask	T_Y3	N/A	-	mV
Uncorrelated bounded high probability jitter	T_UBHPJ	0.15	-	U <sub>lpp</sub>
Duty cycle distortion	T_DCD	0.05	-	U <sub>lpp</sub>
Total jitter	T_TJ	0.30	-	U <sub>lpp</sub>

### 3.7.4.3.4 Level II Short Run Receiver Specifications

Table 29: Level II Short Run Receiver Electrical Input Specifications

Characteristic	Symbol	Reference	Minimal	Typical	Maximum	Units
Rx baud rate (5 Gbps)	R_Baud	Section 10.3.2.2.1	5.00 -0.01%	5.00	5.00 +0.01%	Gbps
Absolute input voltage	R_Vin	Section 10.3.2.2.3	-	-	-	-
Input differential voltage	R_Vdiff	Section 10.3.2.2.3	125	-	750	mVppd
Differential resistance	R_Rdin	Section 10.3.2.2.7	80	100	120	Ohm
Bias voltage source impedance <sup>1</sup> (load types 1 to 3)	R_Zvt	-	-	-	30	Ohm
Differential input return loss (100 MHz to 0.5*R_Baud)	R_SDD11	Section 10.3.2.2.7	-	-	-8	dB
Differential input return loss (0.5*R_Baud to R_Baud)	-	-	-	-	-	-
Common mode input return loss (100 MHz to 0.5*R_Baud)	R_SCC11	Section 10.3.2.2.7	-	-	-6	dB
Termination voltage <sup>1,2</sup>	R_Vtt	R_Vtt floating <sup>4</sup>	Not specified			V
		R_Vtt = 1.2V Nominal	1.2 -8%	-	1.2 +5%	
		R_Vtt = 1.0V Nominal	1.0 -8%	-	1.0 +5%	
		R_Vtt = 0.8V Nominal	0.8 -8%	-	0.8 +5%	

Table 29: Level II Short Run Receiver Electrical Input Specifications (Continued)

Characteristic	Symbol	Reference	Minimal	Typical	Maximum	Units
Input common mode voltage <sup>1,2</sup>	R_Vrcm	R_Vtt floating <sup>3,4</sup>	-0.05	-	1.85	V
		R_Vtt = 1.2V Nominal	720		R_Vtt - 10	mV
		R_Vtt = 1.0V Nominal	535		R_Vtt + 125	mV
		R_Vtt = 0.8V Nominal	475		R_Vtt + 105	mV
Wander divider	n	Section 8.4.5, 8.4.6	-	10	-	-

1. DC Coupling compliance is optional. For Vcm definition, see [Figure 6](#).
2. Receiver is required to implement at least one of the specified nominal R\_Vtt values, and usually implements only one of these values. Receiver is only required to meet R\_Vrcm parameter values that correspond to R\_Vtt values supported.
3. Input common mode voltage for AC-coupled or floating load input with min. T\_Vdiff.
4. For floating load, input resistance must be > 1K Ohm.

### 3.7.4.3.5 Level II Medium Run Receiver Specifications

Table 30: Level II MR Receiver Electrical Input Specifications

Characteristic	Symbol	Reference	Minimum	Typical	Maximum	Units
Rx baud rate (5 Gbps)	R_Baud	Section 10.5.2.2.1	5.00 -0.01%	5.00	5.00 +0.01%	Gbps
Absolute input voltage	R_Vin	Section 10.5.2.2.3	-	-	-	-
Input differential voltage	R_Vdiff	Section 10.5.2.2.3	-	-	1200	mVppd
Differential resistance	R_Rdin	Section 10.5.2.2.7	80	100	120	Ohm
Bias voltage source impedance (load type 1) <sup>1</sup>	R_Zvt	-	-	-	30	Ohm
Differential input return loss (100MHz to 0.5*R_Baud)	R_SDD11	Section 10.5.2.2.7	-	-	-8	dB
Differential input return loss (0.5*R_Baud to R_Baud)			-	-	-	-
Common mode input return loss (100MHz to 0.5*R_Baud)	R_SCC11	Section 10.5.2.2.7	-	-	-6	dB
Input common mode voltage <sup>1,2</sup>	R_Vfcm	Load Type 0 <sup>2</sup>	0	-	1800	mV
		Load Type 1 <sup>1,3</sup>	595	-	R_Vtt - 60	mV
Wander divider	n	Section 8.4.5, 8.4.6	-	10	-	-

1. DC coupling compliance is optional (Load Type 1). Only receivers that support DC coupling are required to meet this parameter.
2. Load Type 0 with min T\_Vdiff, AC-Coupling or floating load. For floating load, input resistance must be > 1K Ohm.
3. For Load Type 1: T\_Vtt and R\_Vtt = 1.2V +5% / -8%.

3.7.4.3.6 Level II Receiver Eye Diagram

For a Level II link the receiver mask it is defined as displayed in the following figure. Specific parameter values for both masks are called out in the following table.

Figure 11: Level II Receiver Input Compliance Mask

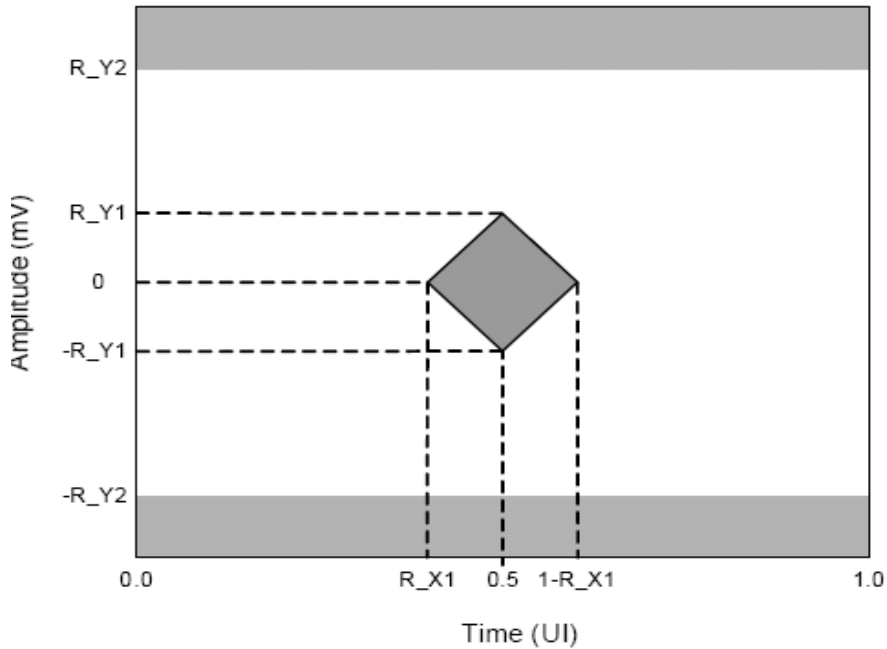

Table 31 defines the parameters for receivers that have an open eye at the far-end. The termination conditions used to measure the received eye are defined in the above Level II Receiver Specification tables.

Table 31: Level II Far-End (Rx) Template Intervals

Characteristic	Symbol	Far-End Value	Units
Eye mask	R_X1	0.30	UI
Eye mask	R_Y1	62.5	mV
Eye mask	R_Y2	375	mV
Uncorrelated bounded high probability jitter	R_UBHPJ	0.15	U <sub>lpp</sub>
Correlated bounded high probability jitter	R_CBHPJ	0.30	U <sub>lpp</sub>
Total jitter (Does not include sinusoidal jitter)	R_TJ	0.60	U <sub>lpp</sub>



### 3.7.5 Reference Clocks – PCCLKP/N and REFCLKP/N

Table 32 lists the PCCLKP/N and REFCLKP/N clock electrical characteristics of the Tsi721.



The clock source that drives the PCCLK inputs must meet all requirements for the common clock architecture defined for the reference clock in the *PCI Express Base Specification (Rev. 2.1)*.

**Table 32: PCCLKP/N and REFCLKP/N Clock Electrical Characteristics**

Symbol	Parameter	Minimum	Typical	Maximum	Unit
$V_{IN\_DIFF}$	Differential input voltage (single-ended peak to peak)	0.3	-	1.0	V
$V_{DC}$	Input level	0	-	2.5	V
$V_{CM}^a$	Common-mode input level	0.15	-	2.0	V
$F_{REFCLK}$	REFCLK clock frequency	100	-	156.25	MHz
$S_{REFCLK}$	REFCLK stability	-100	-	+100	ppm
$T_{J\_REFCLK}$	REFCLK total phase jitter (1 MHz–20 MHz)	-	-	1	ps (rms)
$F_{PCCLK}$	PCCLK clock frequency	100	-	156.25	MHz
$S_{PCCLK}$	PCCLK average frequency accuracy	-300	-	300	ppm
$CCJ_{PCCLK}$	PCCLK cycle-to-cycle jitter	-	-	150	ps
$F_{DUTY}$	Clock duty cycle	40	-	60	%
$T_{ER-RISE}$	Rising edge rate	0.6	-	-	V/ns
$T_{ER-FALL}$	Falling edge rate	0.6	-	-	V/ns
$Z_{in}^b$	Clock input impedance	-	High	-	Ohm

- a. Common-mode voltage must be supplied by the clock source circuit.
- b. Clock termination must be implemented on the circuit board.

PCCLKP/N and REFCLKP/N require a terminated, DC biased, differential clock source. This type of reference clock is usually used in PCIe systems but not in S-RIO systems. Different clock technologies can be used with the Tsi721 provided that proper termination is used.

The following diagrams provide examples of commonly used clock technologies connected to PCCLKP/N and REFCLKP/N.

Figure 12: HCSL to REFCLKP/N / PCCLKP/N

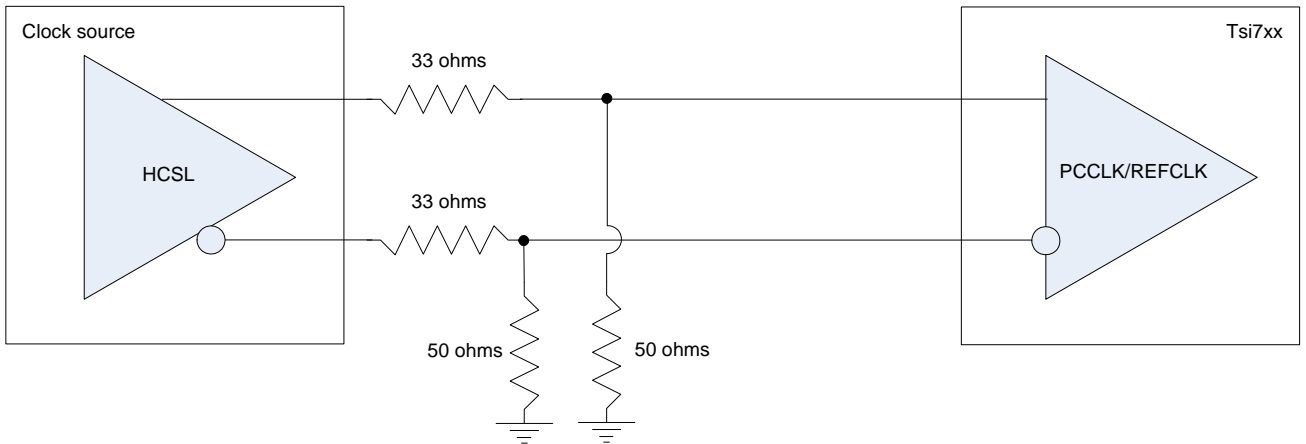

Figure 13: LVDS to REFCLKP/N / PCCLKP/N

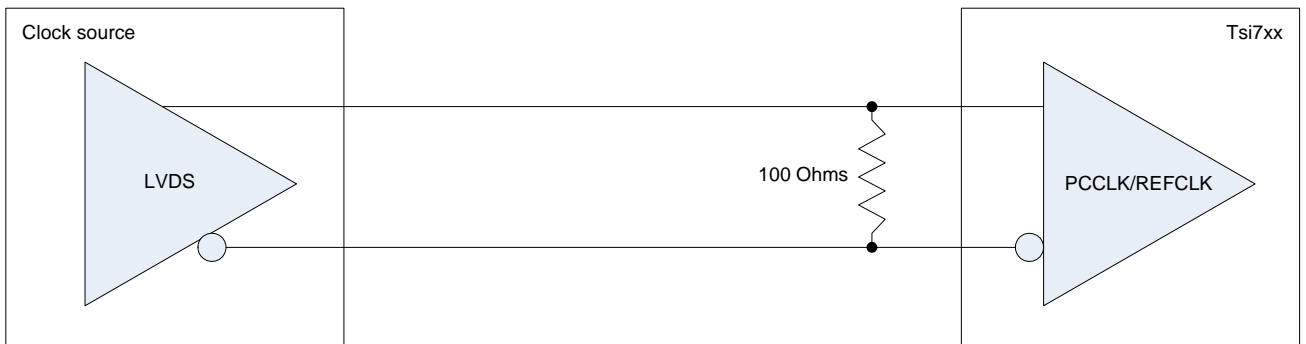

Figure 14: LVPECL to REFCLKP/N / PCCLKP/N

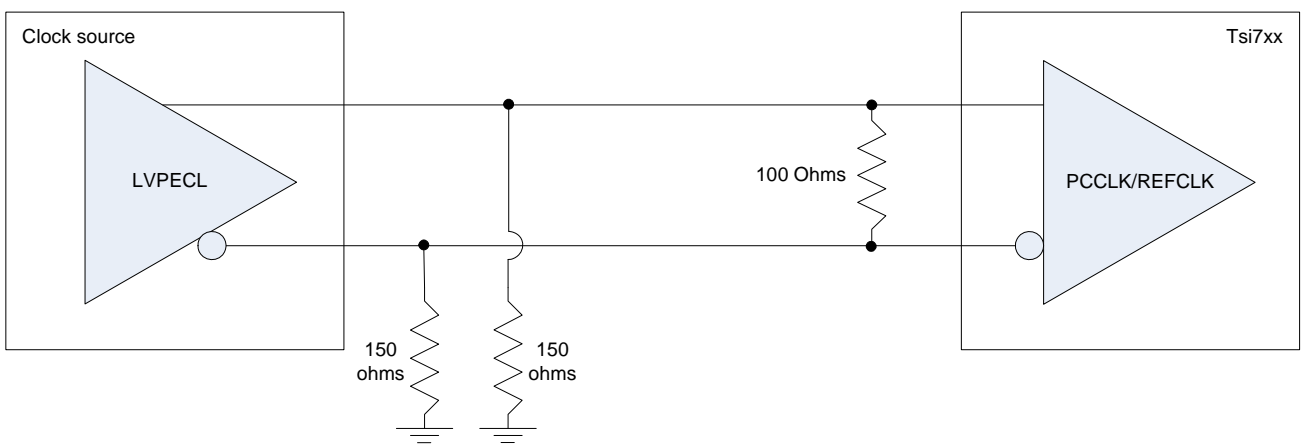
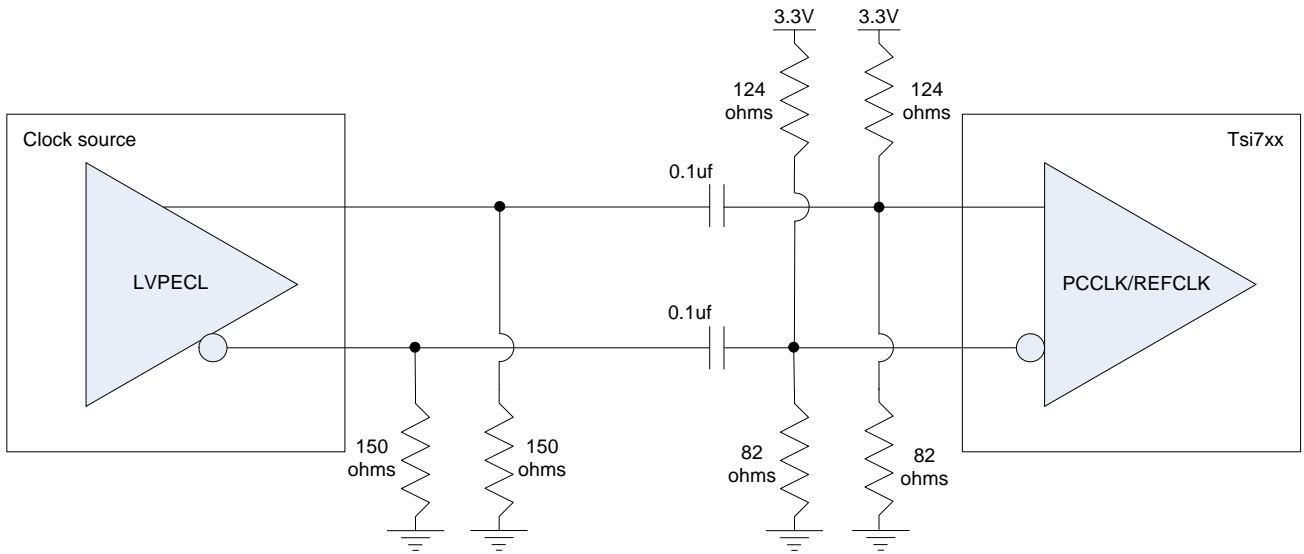

Figure 15: LVPECL to REFCLKP/N / PCCLKP/N



3.7.6 JTAG and Test Interface Signal Timings

The following table lists the AC specifications for Tsi721's JTAG and test interface.

Table 33: JTAG and Test Interface AC Specifications

Symbol	Parameter	Minimum	Maximum	Units	Notes
$T_{BSF}$	TCK frequency	0	25	MHz	-
$T_{BSCH}$	TCK high time	50	-	ns	Measured at 1.5V
$T_{BSCL}$	TCK low time	50	-	ns	Measured at 1.5V
$T_{BSCR}$	TCK rise time	-	25	ns	0.8V to 2.0V
$T_{BSCF}$	TCK fall time	-	25	ns	2.0V to 0.8V
$T_{BSIS1}$	Input setup to TCK	10	-	ns	-
$T_{BSIH1}$	Input hold from TCK	10	-	ns	-
$T_{BSOV1}$	TDO output valid delay from falling edge of TCK. <sup>a</sup>	-	15	ns	-
$T_{OF1}$	TDO output float delay from falling edge of TCK	-	15	ns	-
$T_{BSTRST1}$	TRSTn release before RSTn release	-	10	ns	TRSTn must become asserted while RSTn is asserted during device power-up
$T_{BSTRST2}$	TRSTn release before TMS or TDI activity	1	-	ns	-

a. Outputs precharged to VDD.

3.7.7 I2C Interface Signal Timings

The following table lists the AC specifications for the I2C Interface of the Tsi721.

Table 34: I2C Interface AC Specifications

Symbol	Parameter	Minimum	Maximum	Units	Notes
$F_{SCL}$	I2C_SCLK clock frequency	0	100	kHz	-
$T_{LOW}$	I2C_SCLK clock low time	4.7	-	us	See Notes 1 and 2.
$T_{HIGH}$	I2C_SCLK clock high time	4.0	-	us	See Notes 1 and 2.
$T_{HDDAT}$	Data hold time	0	3.45	us	See Note 2.
$T_{SUDAT}$	Data setup time	250	-	ns	See Note 2.
$T_{SR}$	Rise time of I2C_SCLK and I2C_SD	-	1000	ns	See Note 2.
$T_{SF}$	Fall time of I2C_SCLK and I2C_SD	-	300	ns	See Note 2.
$T_{BUF}$	Bus free time between STOP and START condition	4.7	-	us	See Note 2.
$T_{HDSTA}$	Hold Time (repeated) START condition	4.0	-	us	See Notes 2 and 3.
$T_{SUSTA}$	Setup time for repeated START condition	4.7	-	us	See Note 2.
$T_{SUSTO}$	Setup time for STOP condition	4.0	-	us	See Note 2.

1. Not tested.
2. See timing diagram displayed in [Figure 16](#).
3. After this period, the first clock pulse is generated.

Figure 16: I2C Interface Signal Timings

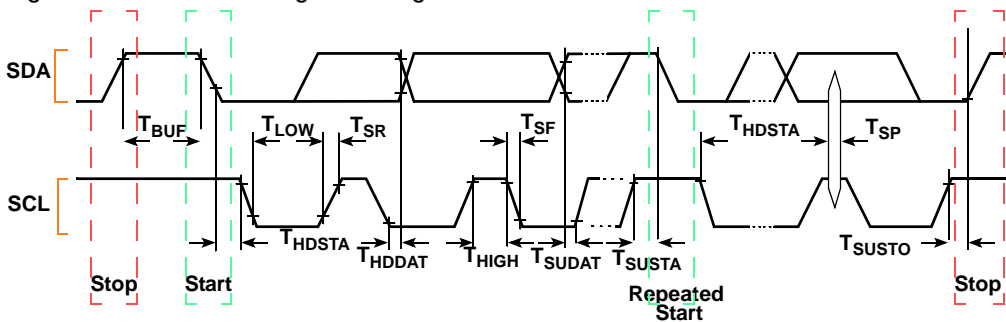

### 3.7.8 GPIO Interface Signal Timings

The following table lists the AC specifications for the GPIO Interface of the Tsi721.

**Table 35: GPIO Interface AC Specifications**

Symbol	Parameter	Minimum	Maximum	Units	Notes
$T_{\text{MIN-HIGH}}$	Minimum signal high time	50	-	ns	-
$T_{\text{MIN-LOW}}$	Minimum signal low time	50	-	ns	-

### 3.7.9 RSTn Signal Timings

The following table lists the RSTn signal timing for the Tsi721 (see PCIe spec 2.1 section 6.6.1 and CEM 2.0 table 2.6.2).

**Table 36: RSTn Signal AC Specifications**

Symbol	Parameter	Minimum	Maximum	Units	Notes
$T_{\text{perst}}$	When asserted, RSTn must remain asserted at least this long	100	-	us	-
$T_{\text{fail}}$	When power become invalid, RSTn must be asserted within this time	-	500	ns	-
$T_{\text{perst-clk}}$	RSTn must remain asserted after any supplied reference clock (REFCLK and PCCLK) is stable	100	-	us	-



## 4. Package Specifications

Topics discussed include the following:

- [Package Dimensions](#)
- [Package Diagrams](#)
- [Thermal Characteristics](#)
- [Moisture Sensitivity](#)

### 4.1 Package Dimensions

Table 37: Package Dimensions

Specification	Description
Package type	FCBGA
Package size	13 x 13 mm
Ball pitch	1 mm
Ball count	143



### 4.3 Thermal Characteristics

Heat generated by the packaged silicon must be removed from the package to ensure the silicon is maintained within its functional and maximum design temperature limits. If heat buildup becomes excessive, the silicon temperature may exceed the temperature limits. A consequence of this is that the silicon may fail to meet the performance specifications and the reliability objectives may be affected.

Failure mechanisms and failure rate of a device has an exponential dependence on the silicon operating temperatures. Therefore, the control of the package, and by extension the junction temperature, is essential to ensure product reliability. The Tsi721 is specified safe for operation when the junction temperature is within the recommended limits as displayed in [Table 12](#).

[Table 38](#) shows the simulated thermal characteristic (Theta JB and Theta JC) of the Tsi721 package.

**Table 38: Junction to Ambient Characteristics – Theta JB/JC**

Interface	Results (C/W)
Theta JB	8.78
Theta JC	0.11

[Table 39](#) shows the simulated junction to ambient characteristics of the Tsi721. The thermal resistance Theta JA characteristics of a package depends on multiple variables other than just the package. In a typical application, designers must consider various system-level and environmental characteristics, such as:

- Package mounting (vertical/horizontal)
- System airflow conditions (laminar/turbulent)
- Heat sink design and thermal characteristics
- Heat sink attachment method
- PWB size, layer count, and conductor thickness
- Influence of the heat dissipating components assembled on the PWB (neighboring effects)

**Table 39: Junction to Ambient Characteristics – Theta JA**

Device	Theta JA (C/W)		
	0 m/s	1 m/s	2 m/s
Tsi721	13.1	12.06	11.4

The results in [Table 39](#) are based on a JEDEC Thermal Test Board configuration (JESD51-9), and do not factor in the system-level characteristics described above. As such, these values are for reference only.

### 4.4 Moisture Sensitivity

The moisture sensitivity level (MSL) for the Tsi721 is 4.





## 5. Ordering Information

Part Number	Temperature Grade	Package Type	Pb (Lead) Free
Tsi721A1-16GCLY	Commercial	FCBGA	No; RoHS Compliant (5of6)
Tsi721A1-16GCLV	Commercial	FCBGA	Yes
Tsi721A1-16GIL	Industrial	FCBGA	No; Leaded Balls and Bumps
Tsi721A1-16GILH	Industrial	FCBGA	No; Leaded Balls
Tsi721A1-16GILY	Industrial	FCBGA	No; RoHS Compliant (5of6)
Tsi721A1-16GILV	Industrial	FCBGA	Yes

